

# Agenda

## Financial Markets

Electronic markets and Market Microstructure

Optimal Trade Execution

Option pricing and hedging

Electronic Market making

Robo-advising

Smart-order routing

## Artificial Intelligence – Neural Networks

What is it?

Data

The Mathematics

Computing Power

The universal approximation theorem

AI and its applications in Finance

Regulatory considerations

Fully connect NNs

RNNs

CNNs

## Deep Reinforcement Learning

SARSA

Q-Learning

Market Impact in Finance

Market Making in Finance

Finance meets Reinforcement Learning meets Deep Learning

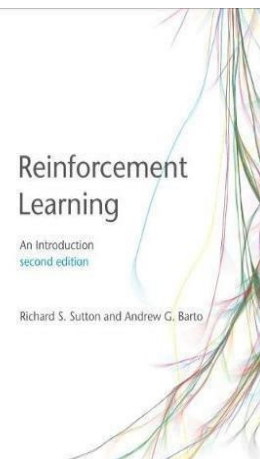
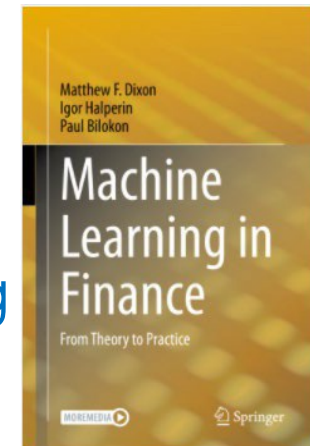



# Artificial Intelligence in Finance

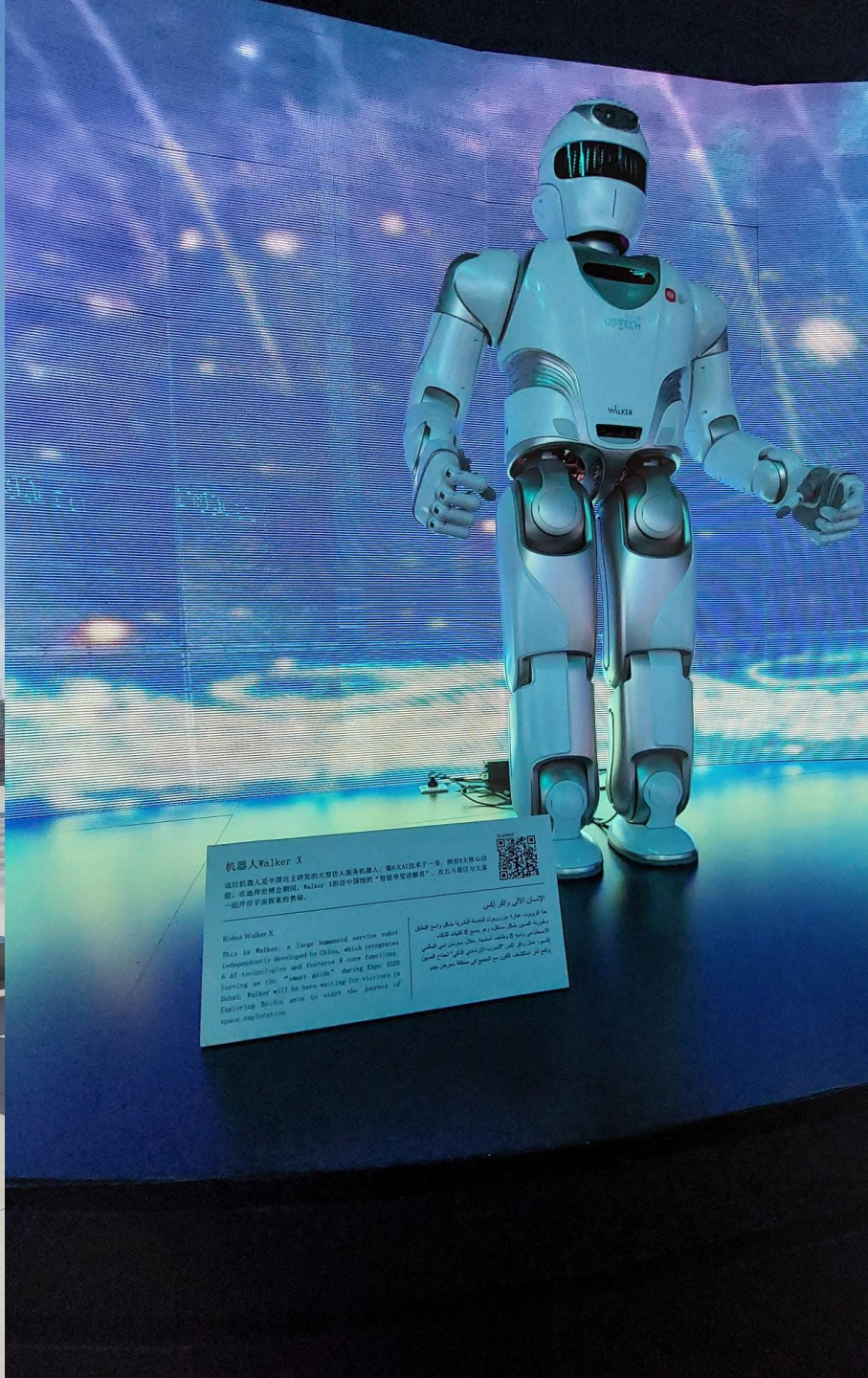

**机器人Walker X**  
这款机器人是由中国自主研发的大型服务机器人，拥有AI技术于一身，拥有AI和语音识别、人脸识别等功能。Walker X是继中国自主研发的“智能服务机器人”、在2020年与全球一起迈向中国高质量发展的未来。

**الروبوت الآلي والفرانسيس**  
هذا الروبوت هو من تطوير الصين الذي يمكنه التعرف على الوجوه والتحدث باللغة الإنجليزية. Walker X هو أول روبوت صيني من نوعه الذي يمكنه التعرف على الوجوه والتحدث باللغة الإنجليزية. Walker X هو أول روبوت صيني من نوعه الذي يمكنه التعرف على الوجوه والتحدث باللغة الإنجليزية.

**Robot Walker X**  
This is Walker, a large humanoid service robot independently developed by China, which integrates AI technology and features a voice recognition and facial recognition function. Walker X is the first Chinese self-developed "intelligent service robot" to go global in 2020, marking a milestone in China's high-quality development.

Serving as the "human guide" during Expo 2020 Dubai, Walker will be here waiting for visitors to explore Dubai and to witness the journey of China's exploration.

main.expo2020.com

AI has started a financial revolution - here's how

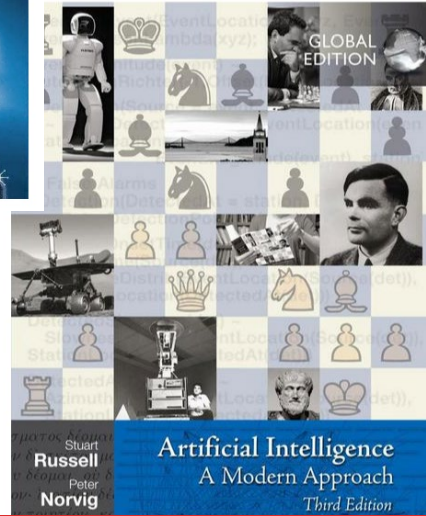
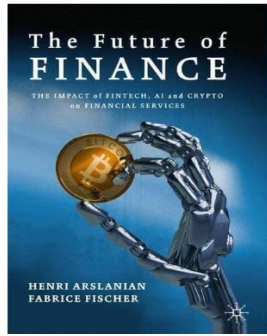

# Preparing Your Business For The Artificial Intelligence Revolution



Dmitry Matskevich Forbes Councils Member  
Forbes Technology Council COUNCIL POST | Paid Program  
Innovation

POST WRITTEN BY  
Dmitry Matskevich

CEO and Co-founder of **Dbrain**, a blockchain platform to collectively build AI apps.



IT STARTUPS  
CHANGING THE RULES

## FINANCIAL REVOLUTION

FUTURE DEVELOPMENT

Whoever leads in artificial intelligence in 2030 will rule the world until 2100

## Financial Revolution: How IT Startups Change The Rules On Wall Street

Forbes

3,529 views | Jun 4, 2020, 03:16pm EDT

## Is AI Overhyped?



Kathleen Walch Contributor  
COGNITIVE WORLD Contributor Group ©  
AI

Feb 22, 2019, 10:24am EST

## The Fintech Revolution Is Here. Can It Help Build A Better Economy?



Jennifer Pryce Contributor ©  
Hedge Funds & Private Equity  
*I connect communities and capital markets*



Forbes

## What Is The Artificial Intelligence Revolution And Why Does It Matter To Your Business?



# What is Artificial Intelligence?

# Dartmouth Summer Research Project on Artificial Intelligence - Summer 1956

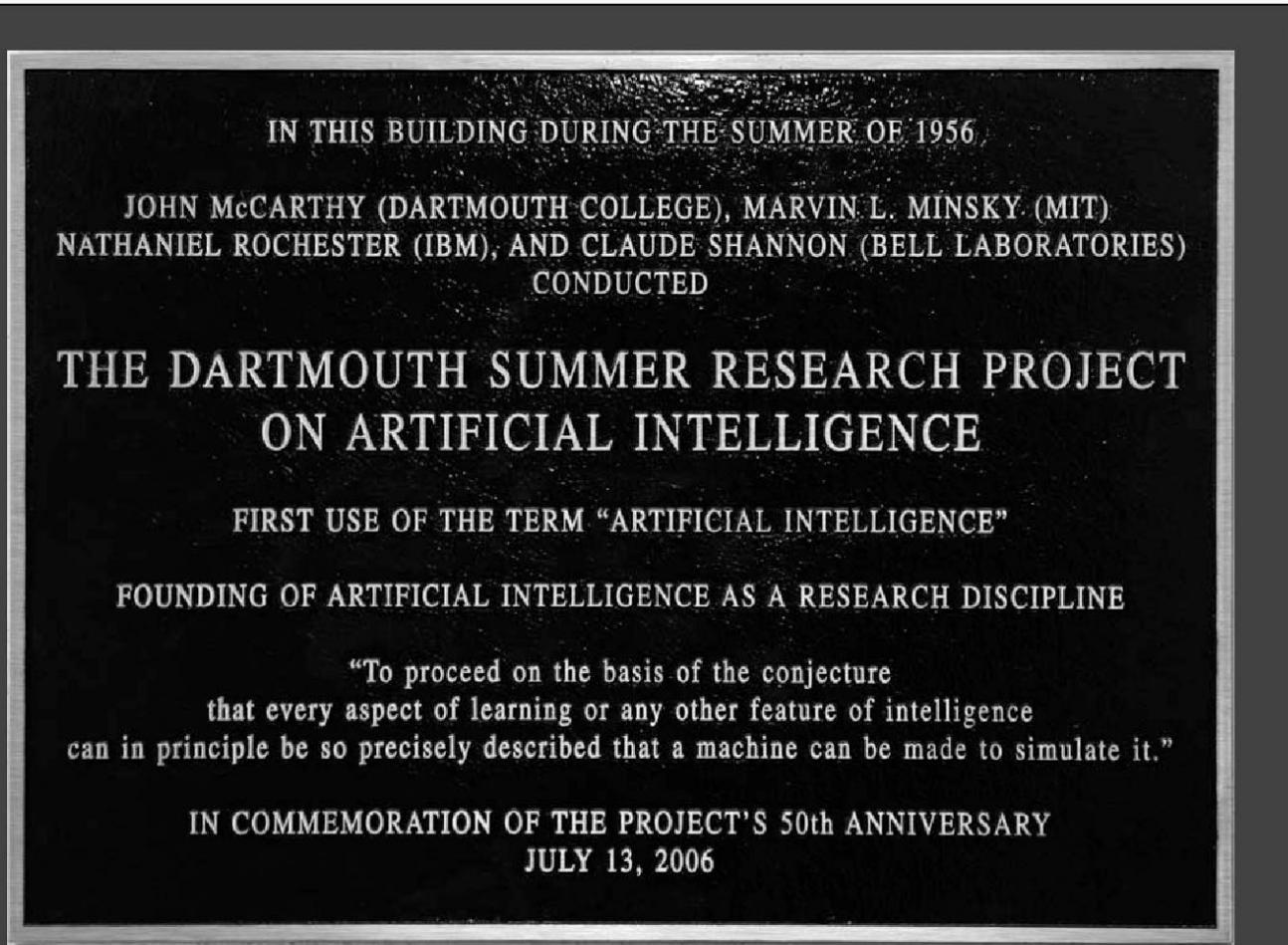

The study is to proceed on the basis of the conjecture that every aspect of learning or **any other feature of intelligence** can in principle be so precisely described that a **machine can be made to simulate it**.

## 1956 Dartmouth Conference: The Founding Fathers of AI



John McCarthy



Marvin Minsky

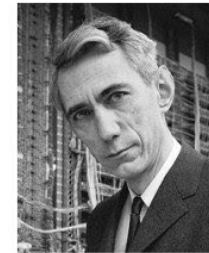

Claude Shannon

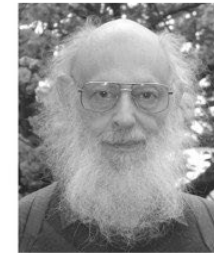

Ray Solomonoff

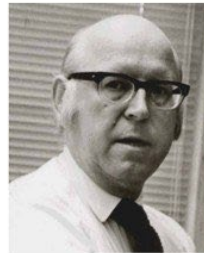

Alan Newell



Herbert Simon



Arthur Samuel

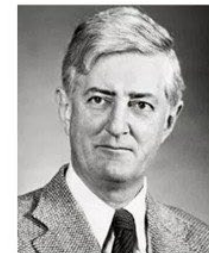

Oliver Selfridge



Nathaniel Rochester



Trenchard More

# Artificial Intelligence Definition - European Commission

*Artificial intelligence refers to systems that display intelligent behaviour by analysing their environment and taking actions – **with some degree of autonomy** – to achieve specific goals.*

*AI-based systems can be purely software-based, acting in the virtual world (e.g. voice assistants, image analysis software, search engines, speech and face recognition systems) or AI can be embedded in hardware devices (e.g. advanced robots, autonomous cars, drones or Internet of Things applications).*

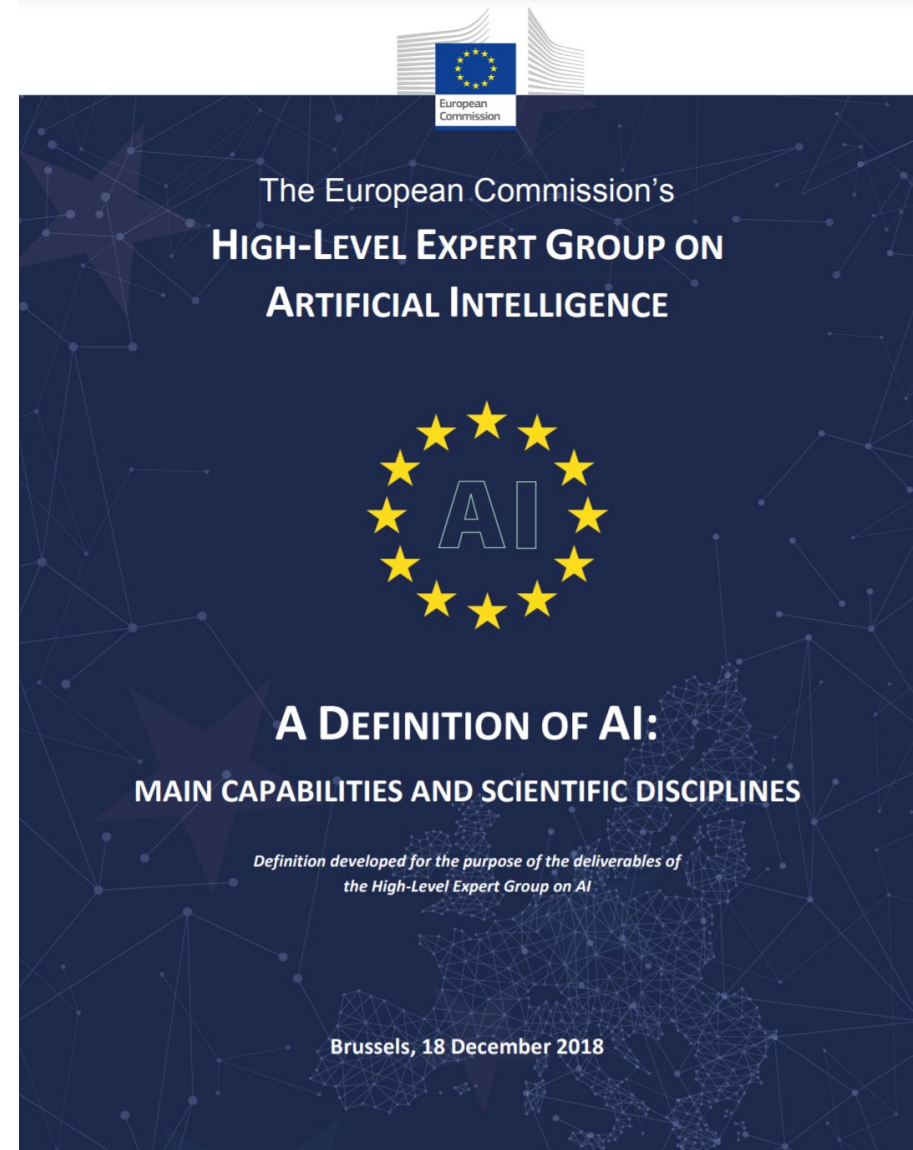

# Machine Learning

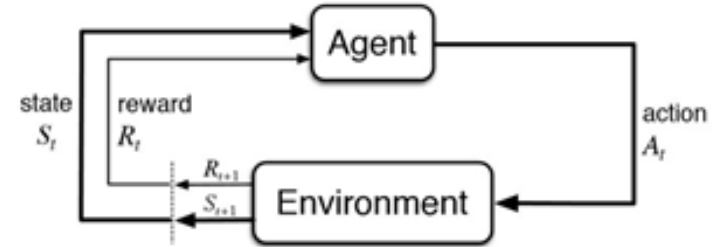

- Machine learning → “a method of designing a sequence of actions **to solve a problem** that optimises automatically through experience and with limited or **no human intervention**” (FSB, 2017)
- Categories of machine learning:
  - **Supervised machine learning**
  - **Unsupervised machine learning**
  - **Reinforcement learning**
  - **Deep Learning**

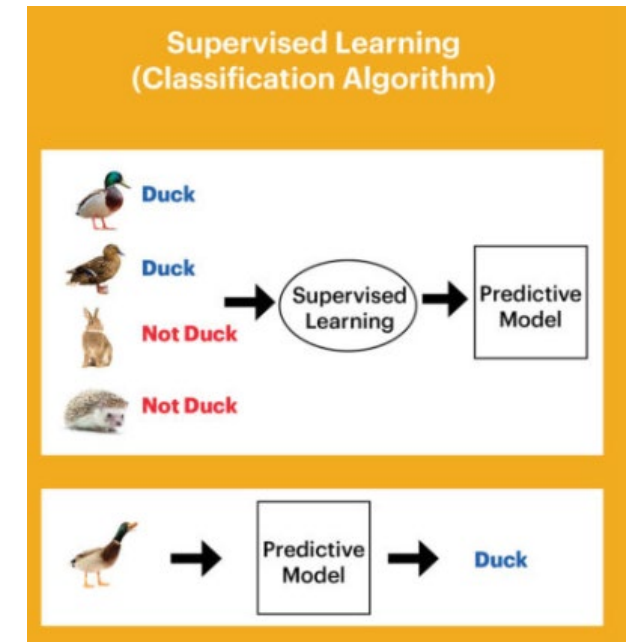
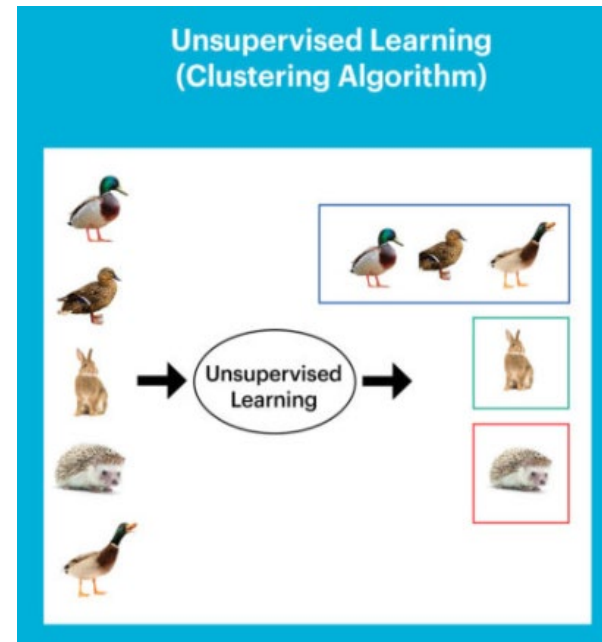
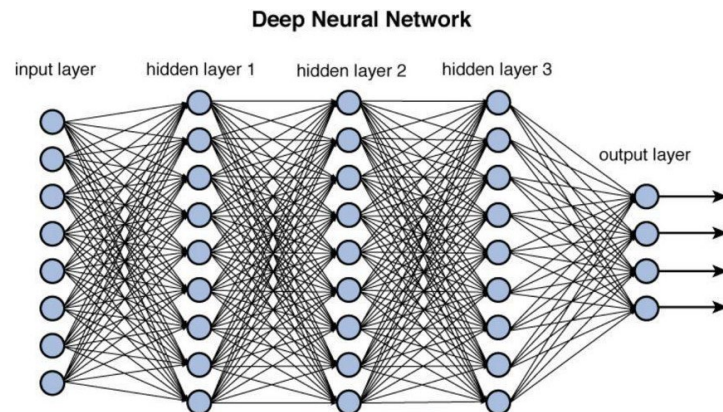

# What is Artificial Intelligence?

## Data

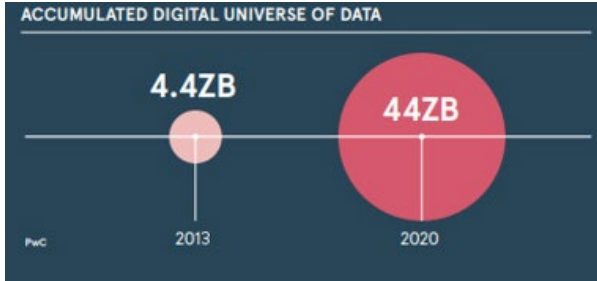

### A day in data

- 65 billion Whatsapp messages
- $10^{15}$  bytes generated by Facebook
- 500m tweets

## The Mathematics

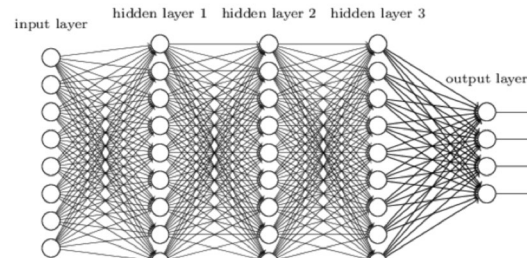

- Machine Learning
- Neural networks
- Numerical optimizations

## Computing power

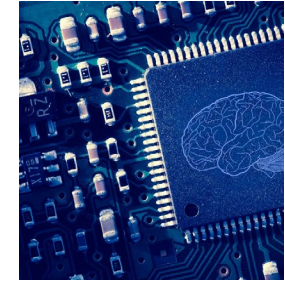

- $10^{21}$  FLOPS (floating point operations per second) globally available
- $10^{12}$ , one trillion, is 80 times the global GDP
- Cost of 1 GFLOP
  - 1945: 1800 trillion USD
  - 2000: 1500 USD
  - 2020: 0.04 USD

# What is Artificial Intelligence?

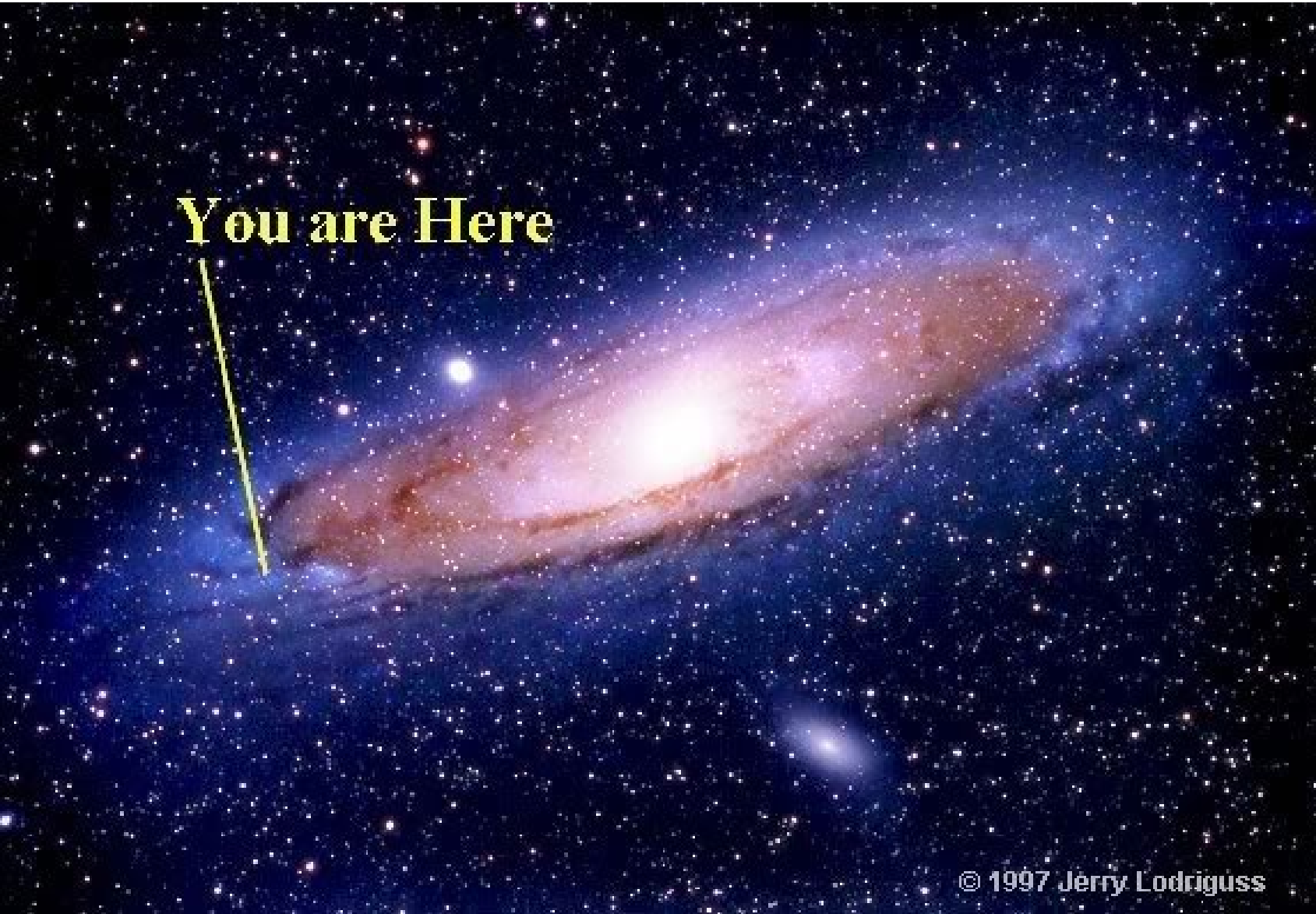

## Computing power

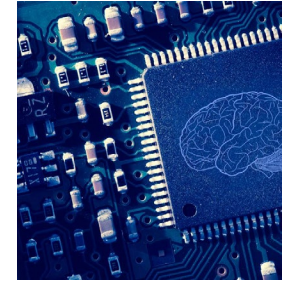

- $10^{21}$  FLOPS (floating point operations per second) globally available
- $10^{12}$ , one trillion, is 80 times the global GDP
- Cost of 1 GFLOP
  - 1945: 1800 trillion USD
  - 2000: 1500 USD
  - 2020: 0.04 USD

# Computing power

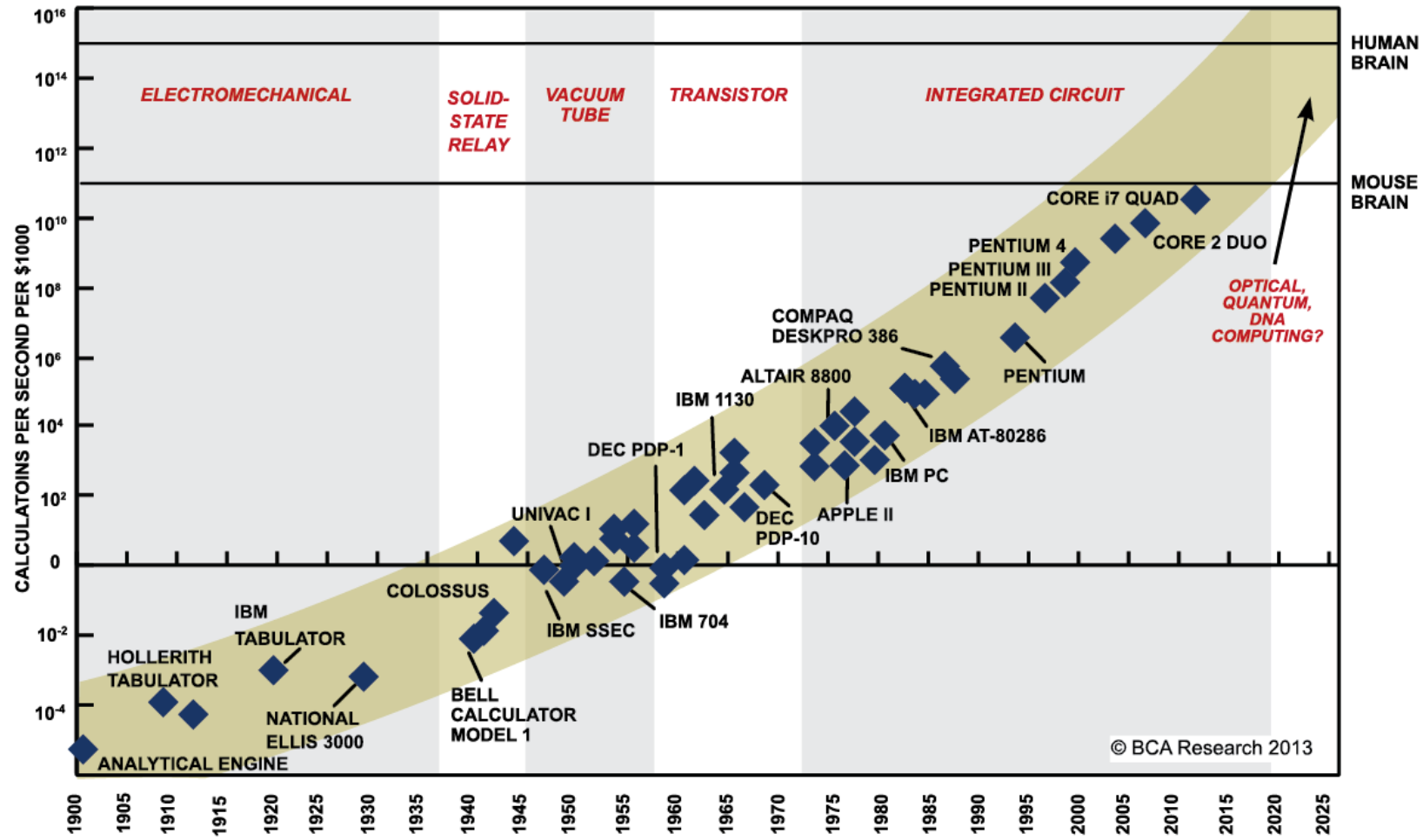

SOURCE: RAY KURZWEIL, "THE SINGULARITY IS NEAR: WHEN HUMANS TRANSCEND BIOLOGY", P.67, THE VIKING PRESS, 2006. DATAPPOINTS BETWEEN 2000 AND 2012 REPRESENT BCA ESTIMATES.

# A DAY IN DATA

The exponential growth of data is undisputed, but the numbers behind this explosion – fuelled by internet of things and the use of connected devices – are hard to comprehend, particularly when looked at in the context of one day

**500m**

tweets are sent every day

Twitter



**4PB**

of data created by Facebook, including

**350m** photos

**100m** hours of video watch time

Facebook Research

**294bn**

billion emails are sent

Radicati Group

**320bn**

emails to be sent each day by 2021

**306bn**

emails to be sent each day by 2020

**3.9bn**

people use emails



**4TB**

of data produced by a connected car

Intel

## DEMYSTIFYING DATA UNITS

From the more familiar "bit" or "megabyte", larger units of measurement are more frequently being used to explain the masses of data.

Unit	Value	Size
<b>b</b> bit	0 or 1	1/8 of a byte
<b>B</b> byte	8 bits	1 byte
<b>KB</b> kilobyte	1,000 bytes	1,000 bytes
<b>MB</b> megabyte	1,000 <sup>2</sup> bytes	1,000,000 bytes
<b>GB</b> gigabyte	1,000 <sup>3</sup> bytes	1,000,000,000 bytes
<b>TB</b> terabyte	1,000 <sup>4</sup> bytes	1,000,000,000,000 bytes
<b>PB</b> petabyte	1,000 <sup>5</sup> bytes	1,000,000,000,000,000 bytes
<b>EB</b> exabyte	1,000 <sup>6</sup> bytes	1,000,000,000,000,000,000 bytes
<b>ZB</b> zettabyte	1,000 <sup>7</sup> bytes	1,000,000,000,000,000,000,000 bytes
<b>YB</b> yottabyte	1,000 <sup>8</sup> bytes	1,000,000,000,000,000,000,000,000 bytes

\*A lowercase "b" is used as an abbreviation for bits, while an uppercase "B" represents bytes.

**65bn**

messages sent over WhatsApp and two billion minutes of voice and video calls made

Facebook



**463EB**

of data will be created every day by 2025

ibc

**95m**

photos and videos are shared on Instagram

Instagram Business



**28PB**

to be generated from wearable devices by 2020

Statista



Searches made a day **5bn**

Searches made a day from Google **3.5bn**

Smart Insights



## ACCUMULATED DIGITAL UNIVERSE OF DATA

**4.4ZB**

**44ZB**

2013

2020

PwC

# Artificial Intelligence techniques – The Mathematics

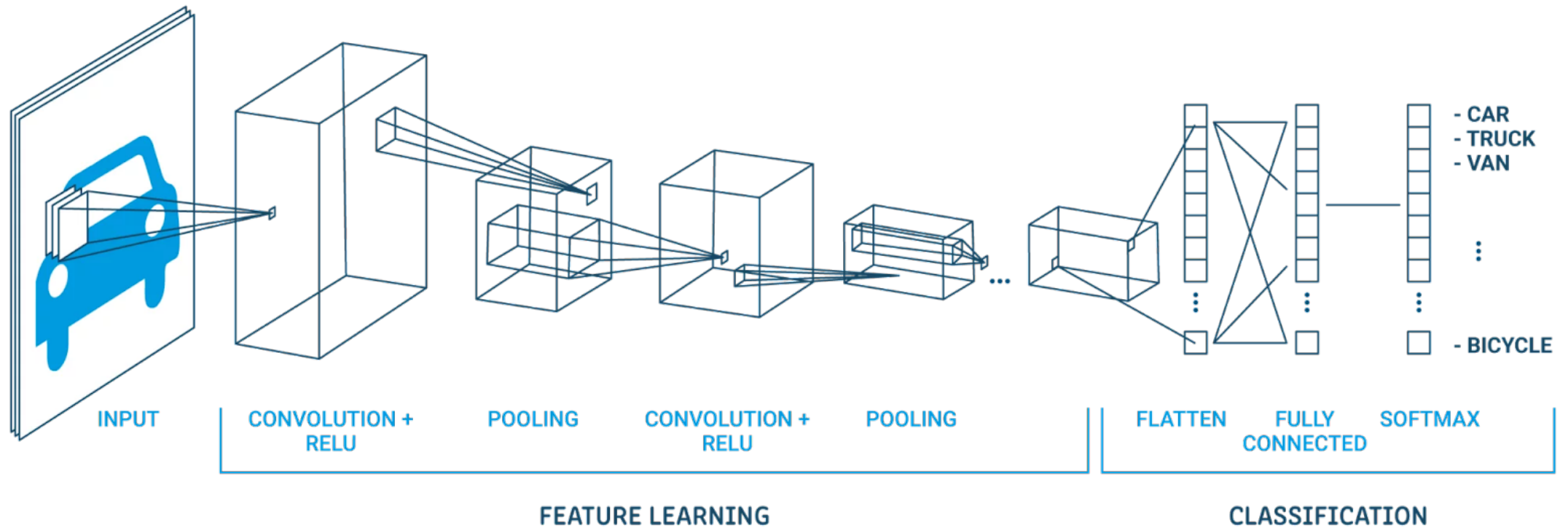

# The Mathematics

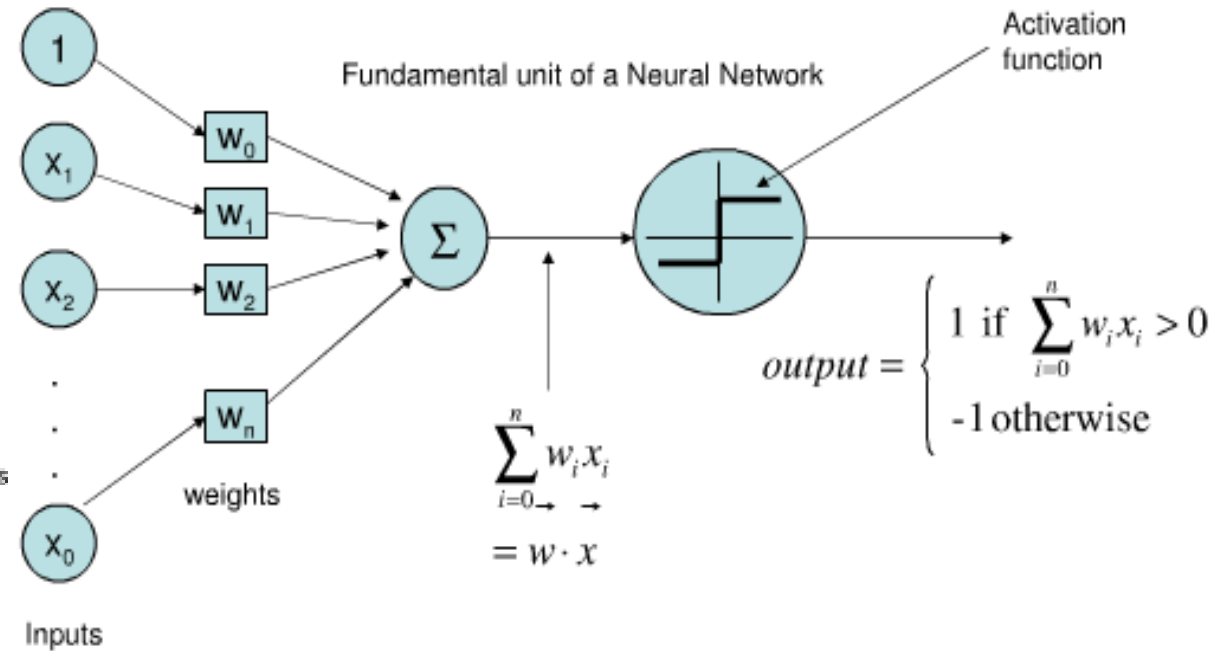
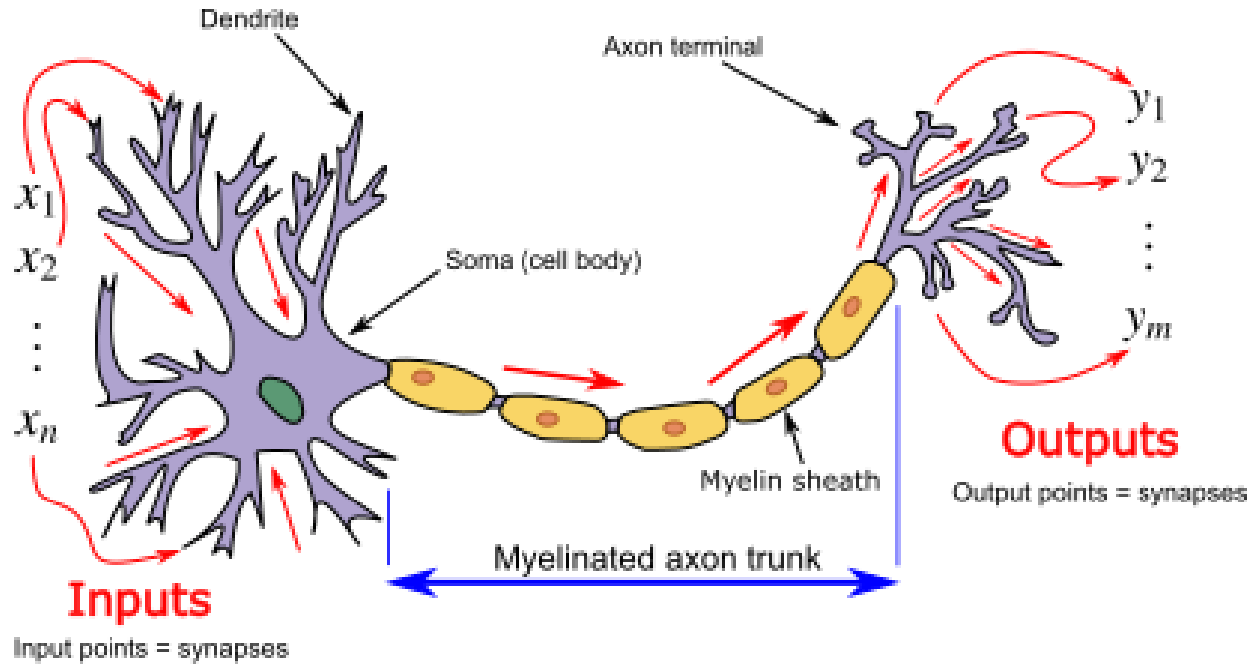

$$f : \mathbb{R}^n \rightarrow \mathbb{R}^m$$

Neural networks (Artificial Intelligence) are functions

# Neural networks and the universal approximation theorem

---

# Neural networks and the universal approximation theorem

Neural networks can approximate (almost) arbitrary mathematical functions

Cybenko (1989) states that any continuous mathematical function on a compact domain can be **approximated with any precision** by an appropriate neural network with sufficient width and depth

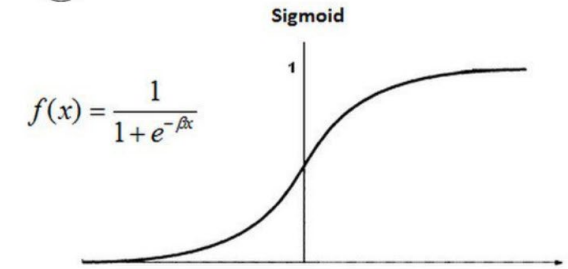
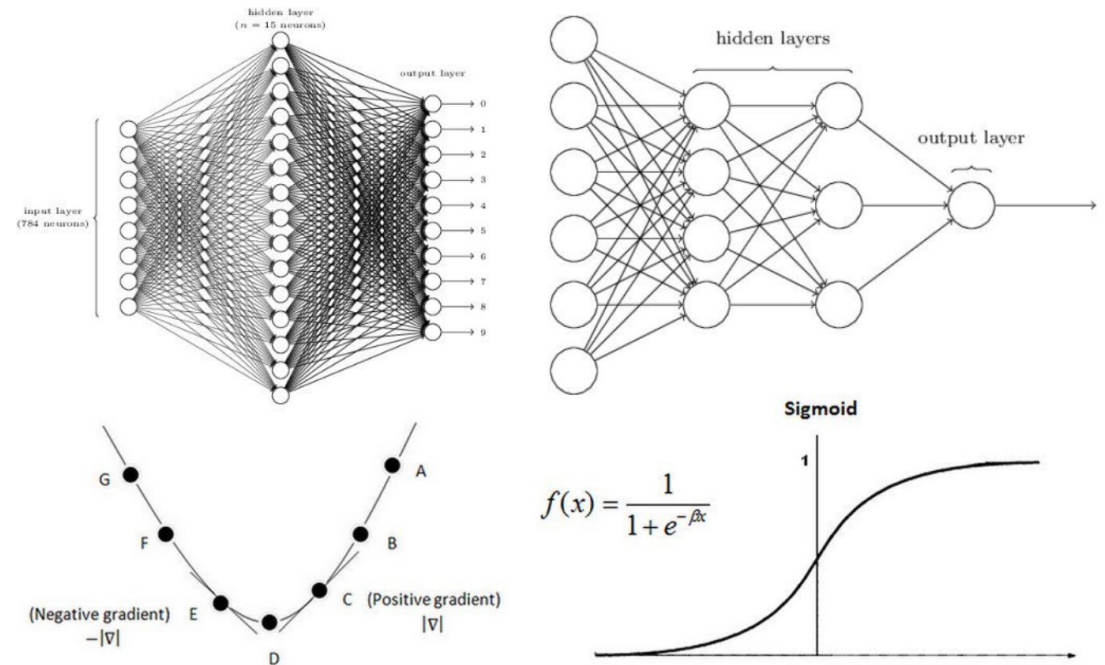

Neural networks are the most powerful functions we have ever had

# Neural networks

## A mostly complete chart of Neural Networks

©2019 Fjodor van Veen & Stefan Leijnen asimovinstitute.org

- Input Cell
- Backfed Input Cell
- △ Noisy Input Cell
- Hidden Cell
- Probabilistic Hidden Cell
- △ Spiking Hidden Cell
- Capsule Cell
- Output Cell
- Match Input Output Cell
- Recurrent Cell
- Memory Cell
- △ Gated Memory Cell
- Kernel
- Convolution or Pool

Perceptron (P)

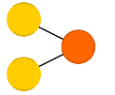

Feed Forward (FF)

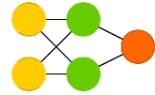

Radial Basis Network (RBF)

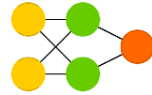

Deep Feed Forward (DFF)

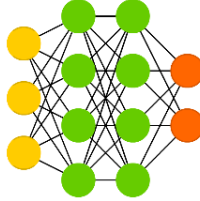

Deep Convolutional Network (DCN)

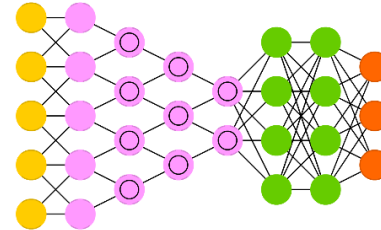

Deconvolutional Network (DN)

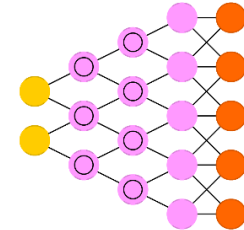

Deep Convolutional Inverse Graphics Network (DCIGN)

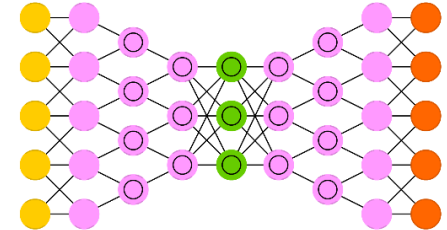

Recurrent Neural Network (RNN)

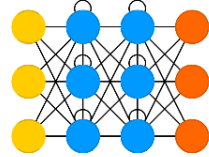

Long / Short Term Memory (LSTM)

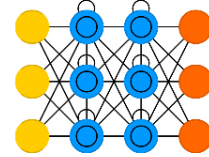

Gated Recurrent Unit (GRU)

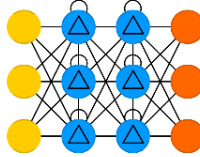

Generative Adversarial Network (GAN)

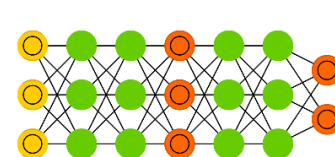

Liquid State Machine (LSM)

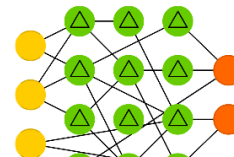

Extreme Learning Machine (ELM)

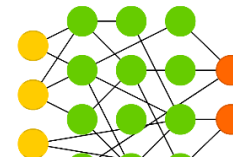

Echo State Network (ESN)

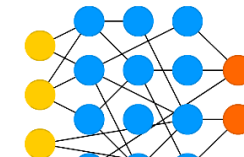

Auto Encoder (AE)

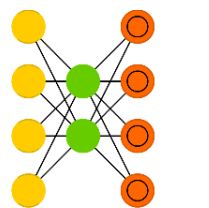

Variational AE (VAE)

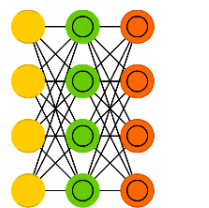

Denosing AE (DAE)

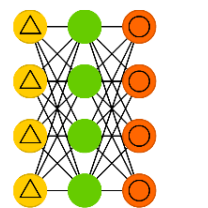

Sparse AE (SAE)

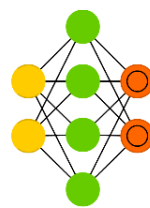

Deep Residual Network (DRN)

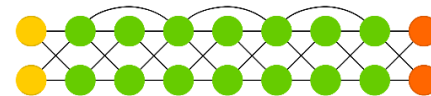

Differentiable Neural Computer (DNC)

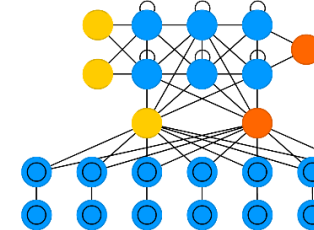

Neural Turing Machine (NTM)

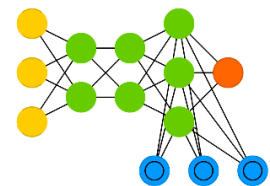

Markov Chain (MC)

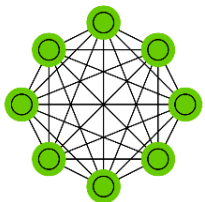

Hopfield Network (HN)

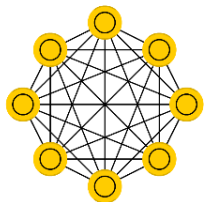

Boltzmann Machine (BM)

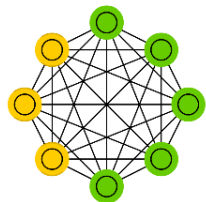

Restricted BM (RBM)

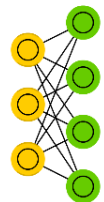

Deep Belief Network (DBN)

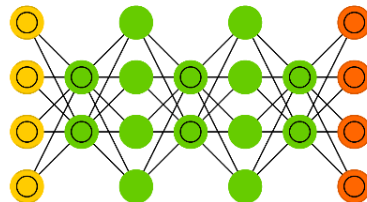

Capsule Network (CN)

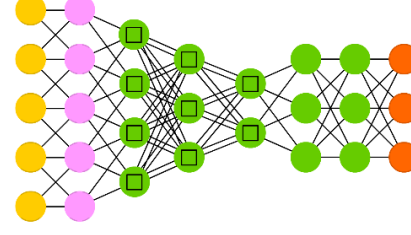

Kohonen Network (KN)

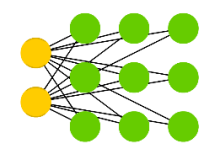

Attention Network (AN)

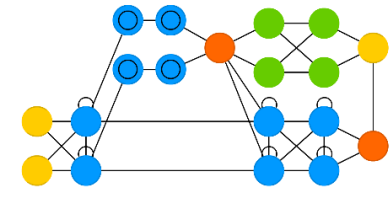



# History of Artificial Intelligence

## Antiquity

Greek myths  
Sacred  
mechanical  
statues built  
in Egypt and  
Greece were  
believed to  
be capable  
of wisdom  
and emotion.



## Symbolic AI 1956 – 1974

"Machines  
will be  
capable,  
within twenty  
years, of  
doing any  
work a man  
can do."



## Boom 1980 1987

The rise of  
expert  
systems  
  
The money  
returns: the  
Fifth  
Generation  
project

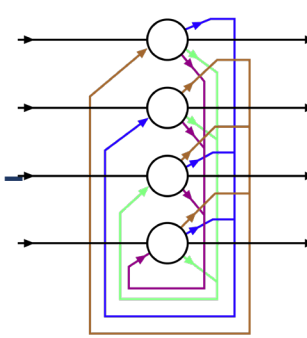

## AI 1993 – 2011

Milestones  
and Moore's  
law  
  
Intelligent  
agents  
  
AI behind the  
scenes - AI  
had solved a  
lot of very  
difficult  
problems



## The birth of AI 1952 – 1956

Turing's test  
Dartmouth  
Workshop  
1956

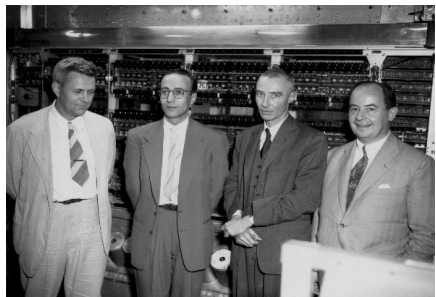

## The first AI winter 1974 – 1980

Limited  
computer power  
Intractability and  
the  
combinatorial  
explosion  
  
The end of  
funding



## Bust: the second AI winter 1987 – 1993

Sudden  
collapse of  
the market  
for  
specialized  
AI hardware  
in 1987

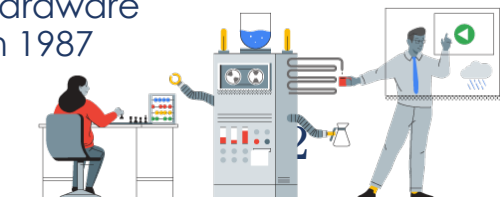

## Deep learning, big data and artificial intelligence: 2011 – present

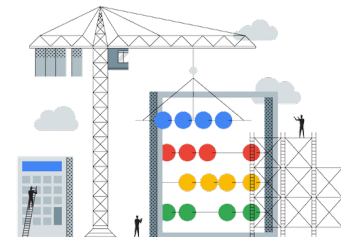

# AI Coins



# A GLOBAL LOOK AT R&D SPENDING

The companies and nations that are leading the way in innovation and research



The G20 accounts for **92%** of global spending on research



**94%** of patents granted by the US Patent and Trademark Office stem from G20 countries

## R&D Expenditure as a percentage of GDP

Select G20 countries; 2015

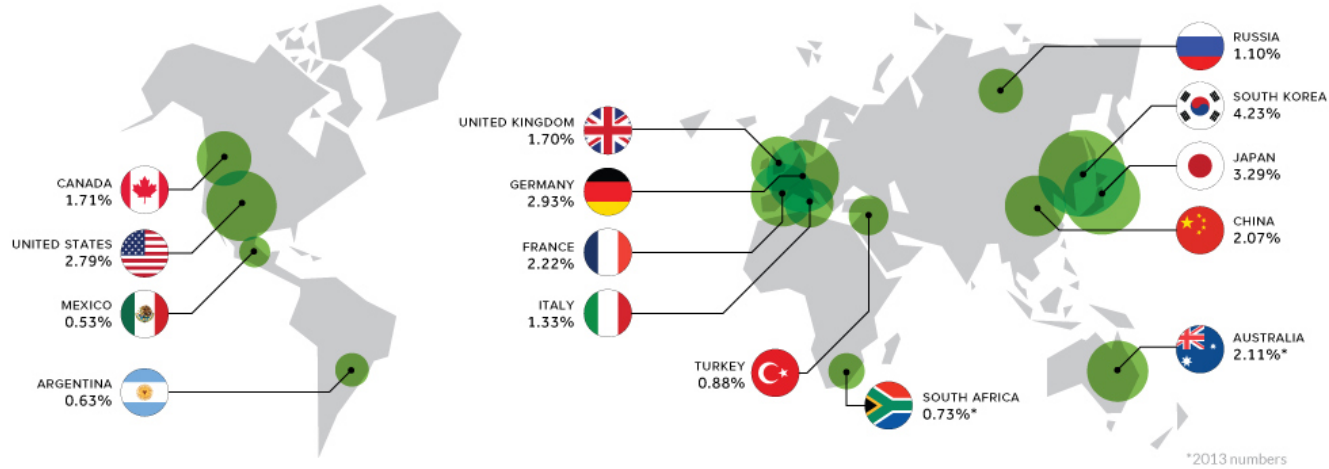

## Top 5 Jurisdictions by R&D Expenditure (2015)

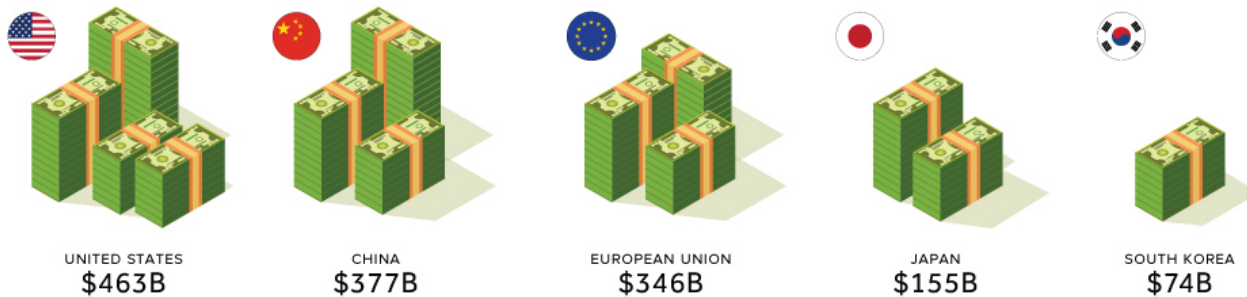

# AI Readiness

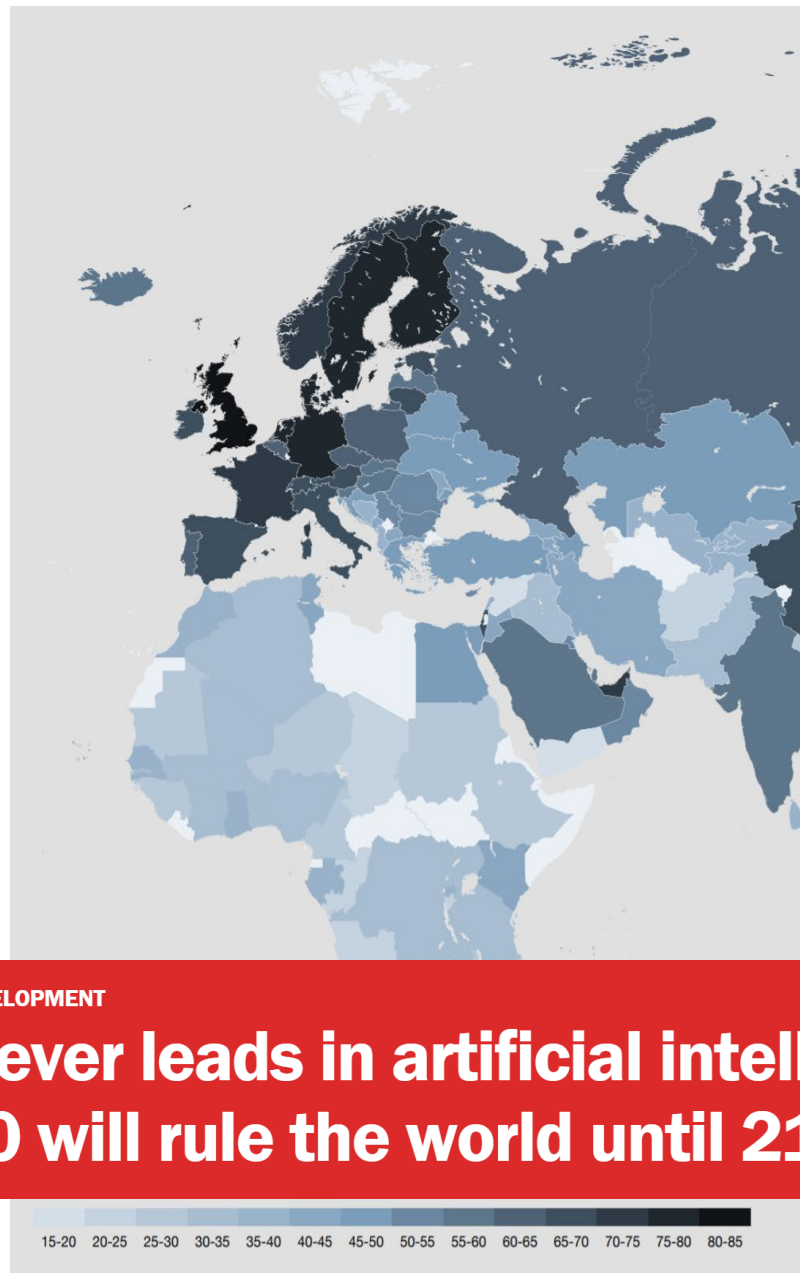
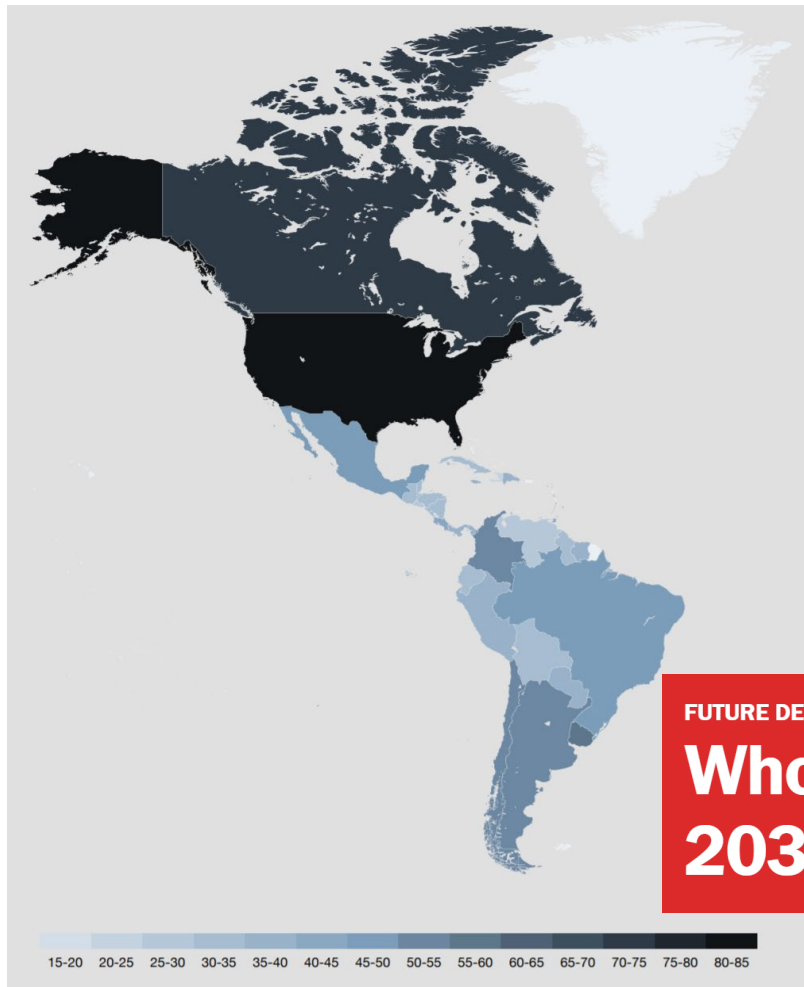

**FUTURE DEVELOPMENT**  
**Whoever leads in artificial intelligence in 2030 will rule the world until 2100**



# **A biased tour through AI in Finance Research: Data Science, Fintech and Blockchain Technology**

# Artificial Intelligence is impacting all business areas

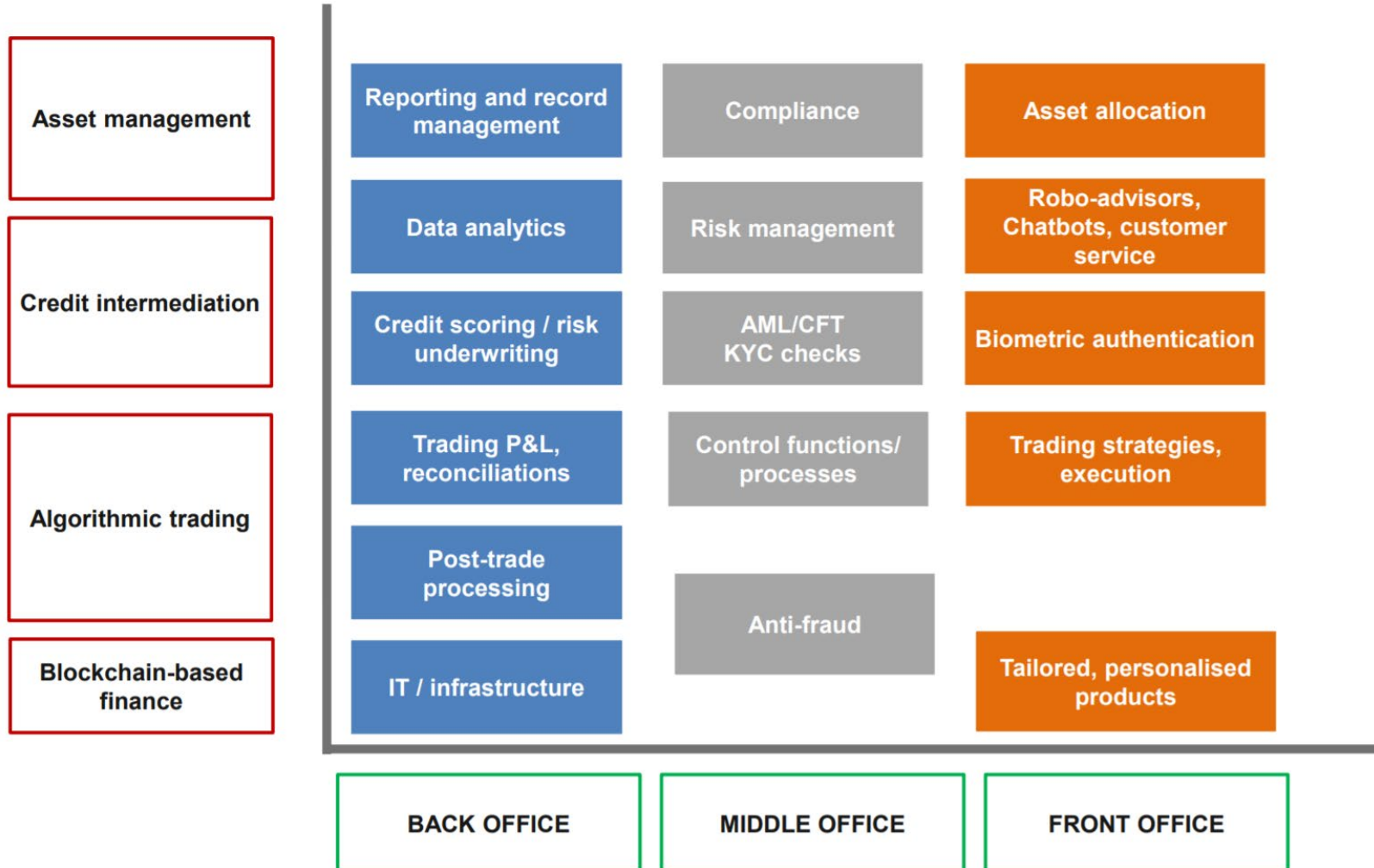

Source: OECD staff illustration.

# Value creation by Artificial Intelligence

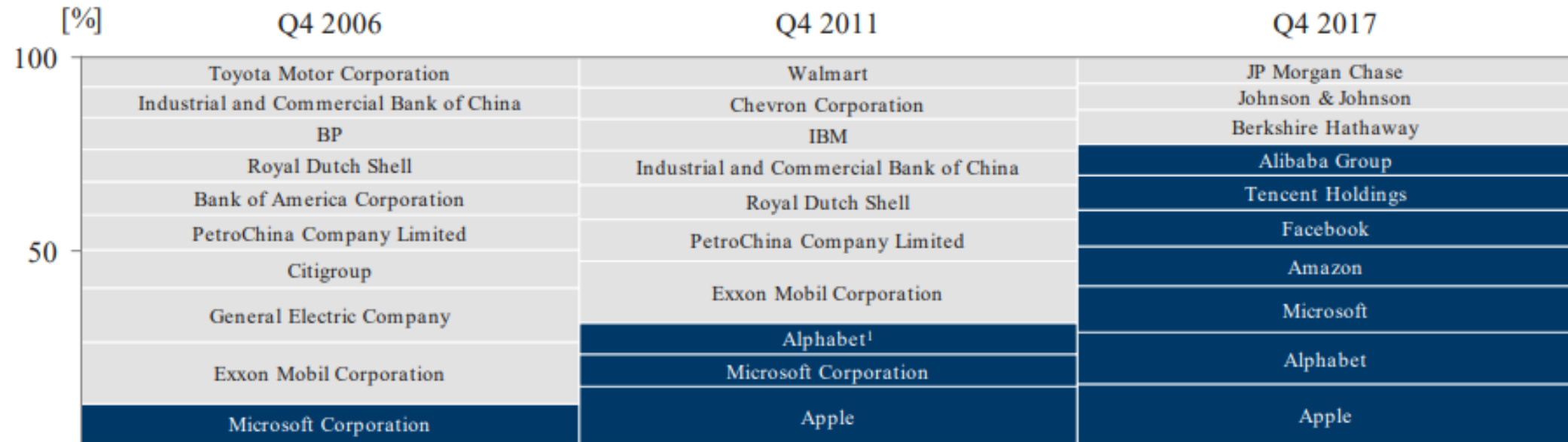

**Proportion of companies with data-driven business models among the top 10 companies by market capitalization**

Source: BAFIN Report (2018)

# Top 10 AI countries

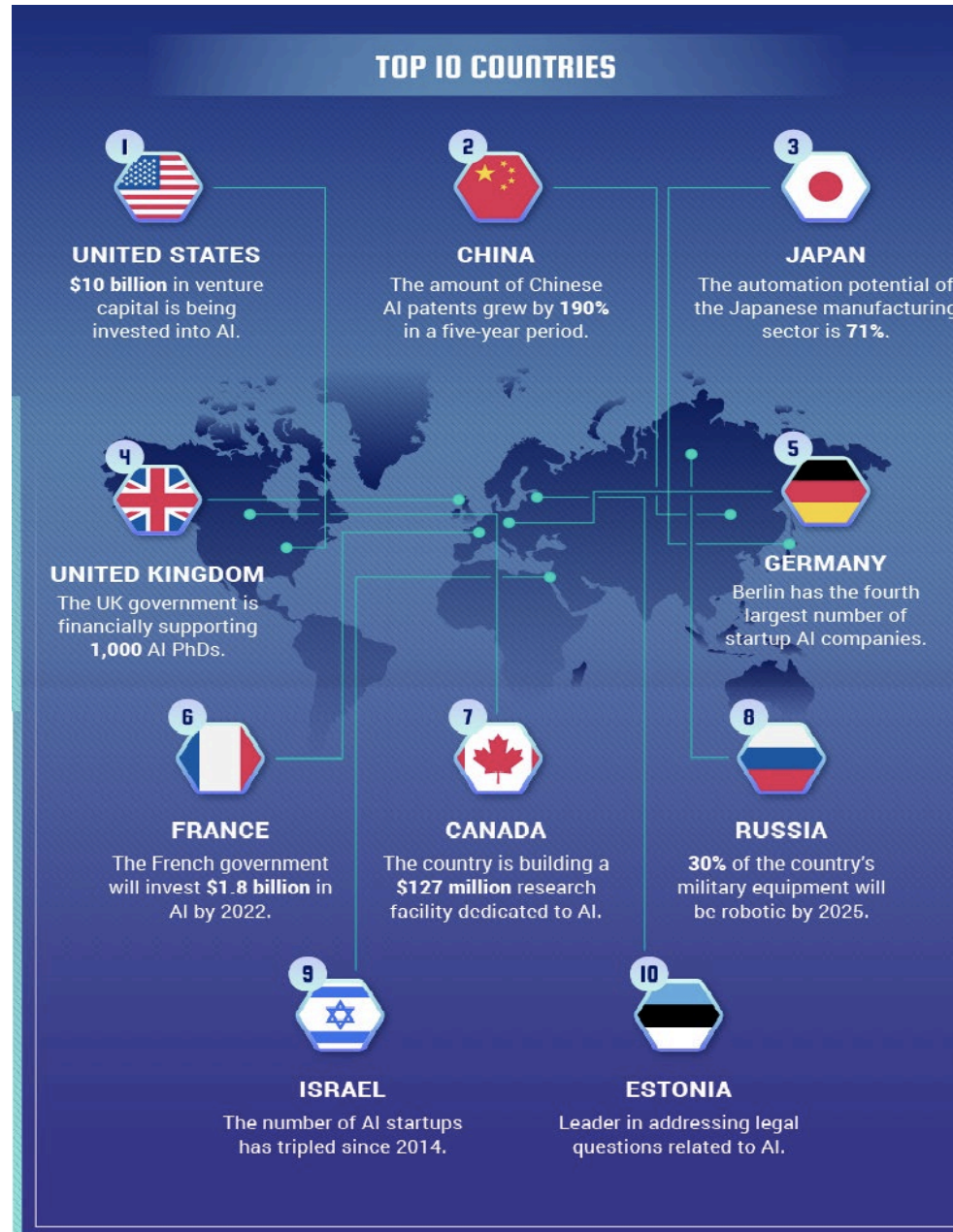

# A biased tour through AI research in Finance

## Fintech and Risk Management



100+ researchers from 15 European Universities

- Detecting Fraud in Blockchain payments
- Peer-to-peer lending
- Explainable AI
- Credit Risk Network models

## Fintech and AI in Finance



200+ researchers from 38 countries



## Reinforcement learning for Finance

- Reinforcement learning for trading and forecasting financial markets

frontiers  
in Artificial Intelligence

REVIEW article  
Front. Artif. Intell., 31 May 2021 | <https://doi.org/10.3389/rai.2021.668465>

### The Applicability of Self-Play Algorithms to Trading and Forecasting Financial Markets

Jan-Alexander Posth<sup>1\*</sup>, Piotr Kotlarz<sup>2,3</sup>, Branka Hadji Misheva<sup>2</sup>, Joerg Osterrieder<sup>2,4</sup> and Peter Schwendner<sup>1</sup>

# A biased tour through AI research in Finance II

## Credit risk models

- Towards Explainable Artificial Intelligence and Machine Learning in Credit Risk Management

## Peer-to-peer lending

### Network-based credit risk models

- Network-based feature extraction techniques
- The use of multiple networks in feature extraction
- bagging and hyper-parameter tuning

## Reinforcement learning for Finance

- Limit order book case study
- Recommender systems
- Factor investing
- Multi-agent Reinforcement Learning

# A biased tour through AI research in Finance III

## Generative Adversarial Networks

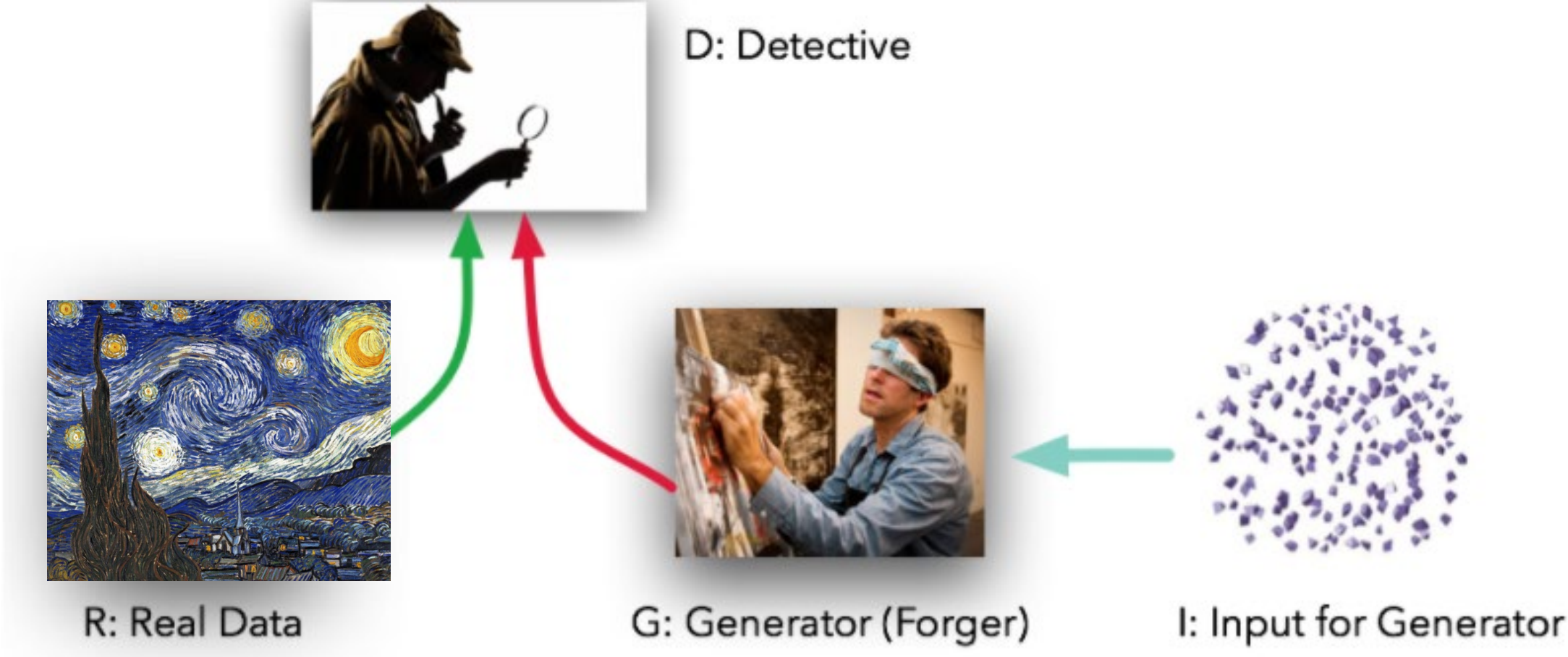

# A biased tour through AI research in Finance IV

## Generative Adversarial Networks

$$\min_{\mathcal{G}} \max_{\mathcal{D}} E_x [\log(\mathcal{D}(x))] + E_z [\log(1 - \mathcal{D}(\mathcal{G}(z)))]$$

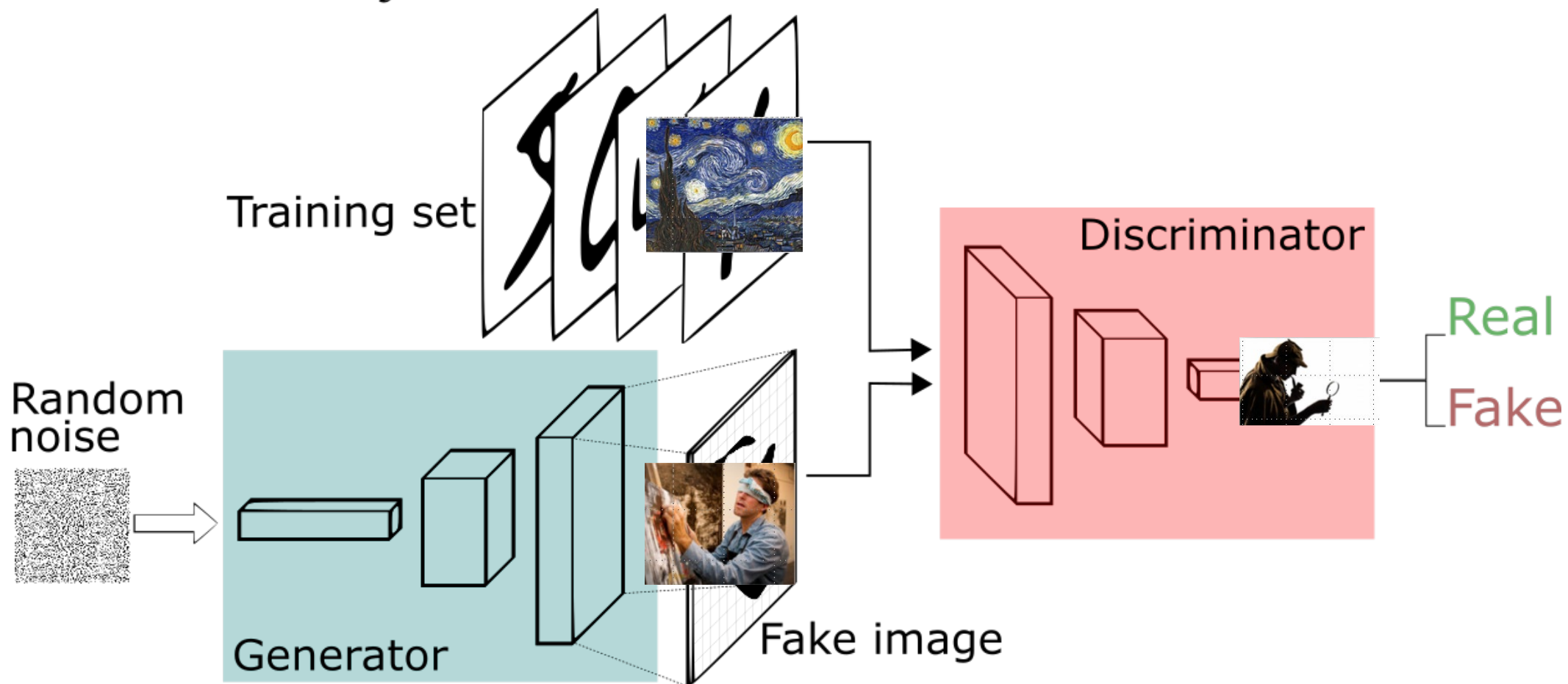

# A Detour – Nash Equilibrium

## GANs and Nash Equilibrium

The GAN framework is a **non-convex, two-player, non-cooperative game** with continuous, high-dimensional parameters, in which each player wants to minimize its cost function.

The optimum of this process takes the name of Nash Equilibrium.

GANs are typically trained using *gradient-descent* techniques that are designed to find the low value of a cost function and not find the Nash Equilibrium of a game

John Forbes Nash Jr.

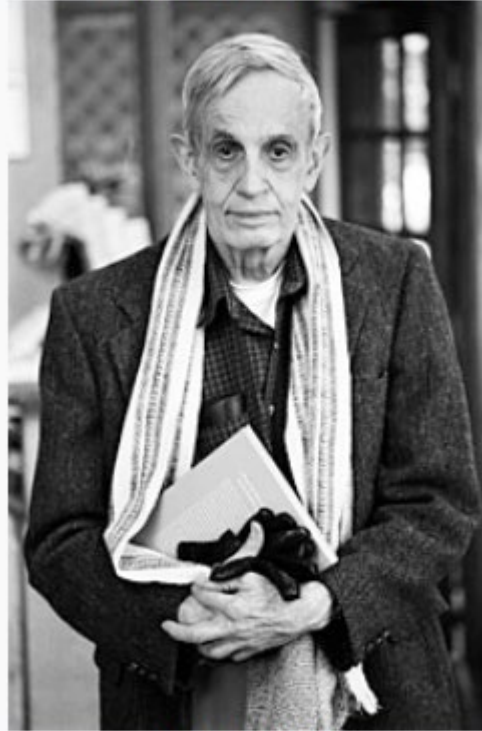

Nash in 2006

What is a Nash Equilibrium?

No participant can gain by a unilateral change of strategy if the strategies of the others remain unchanged



# A biased tour through AI research in Finance V

## Electronic Signature on the Blockchain

## Blockchain-based Fair Trade

## Virtual currencies

### Qualified electronic signature on the blockchain

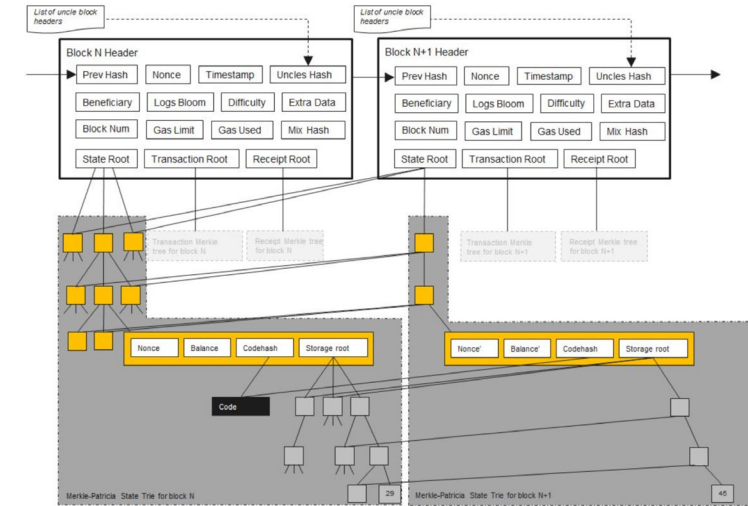
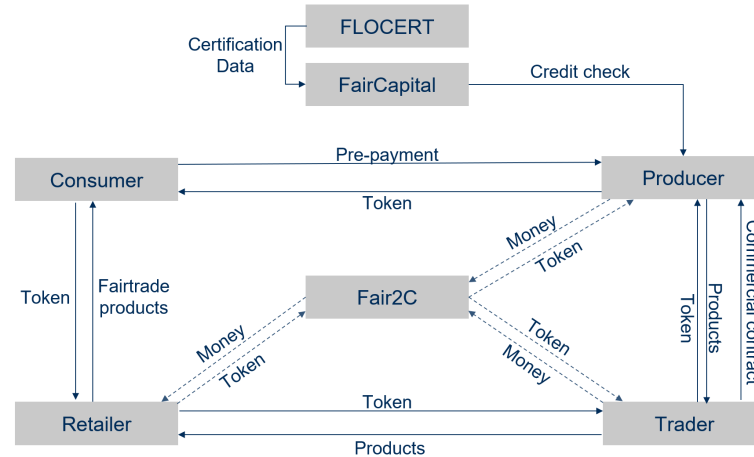
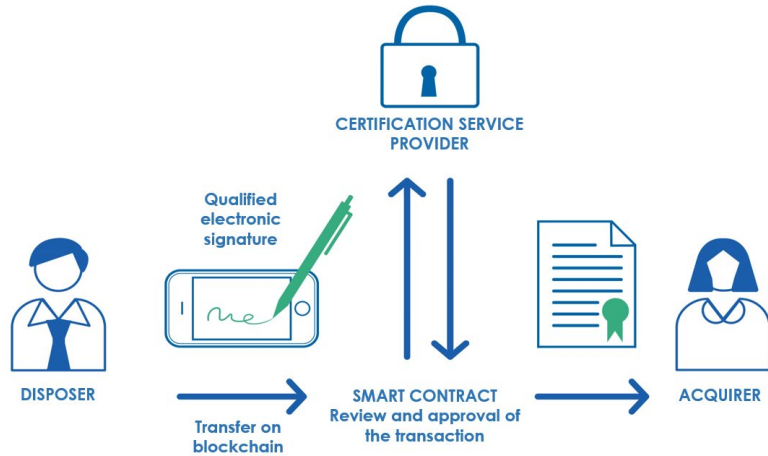

# The AI framework

Input Data

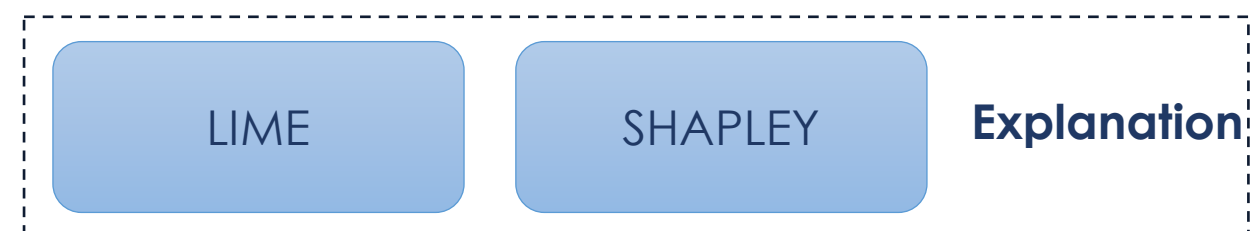
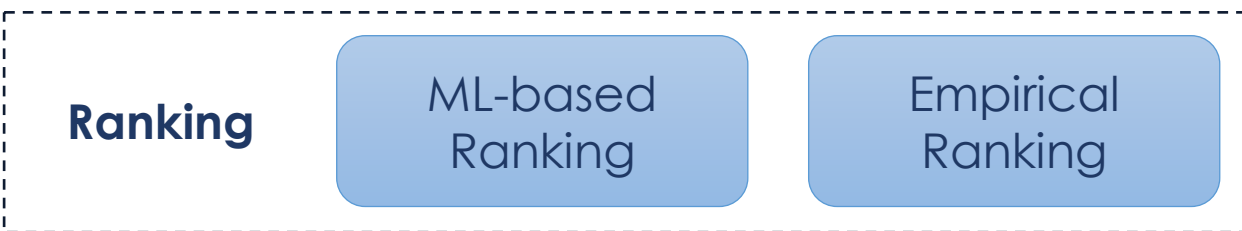
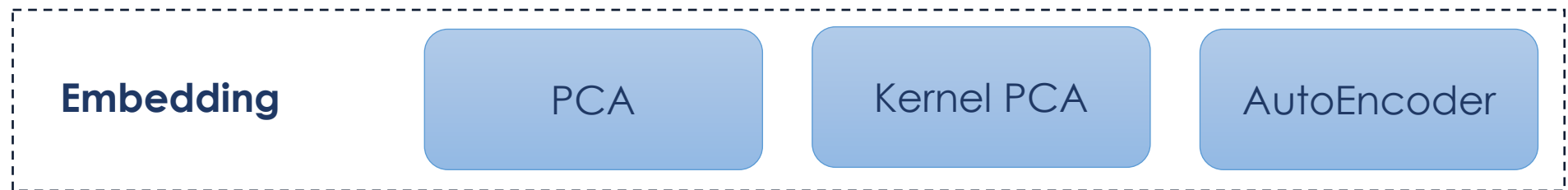
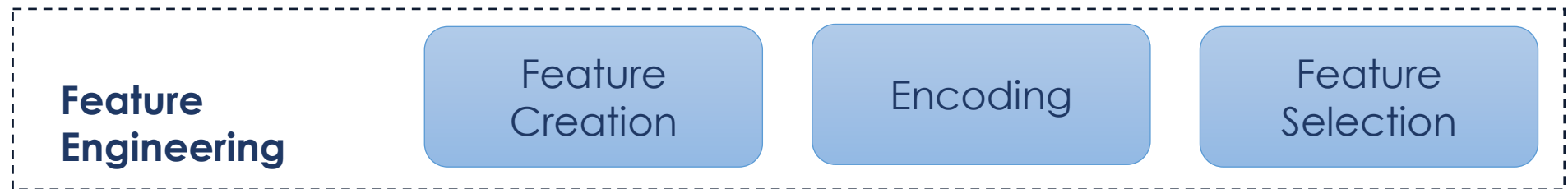



**Regulatory aspects**

# The Need for eXplainable AI

It is not clear how variables are being combined to make predictions!

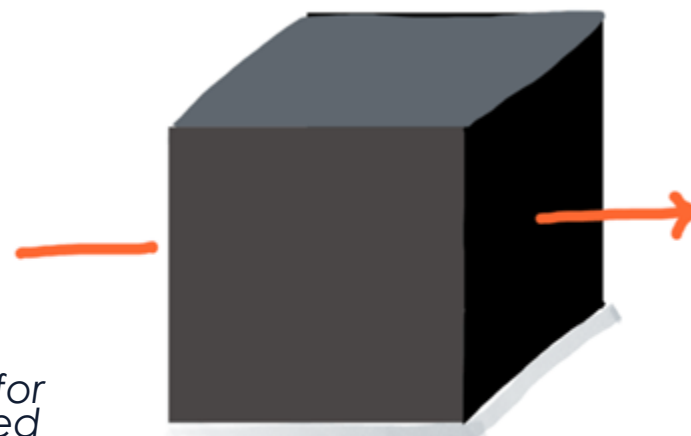
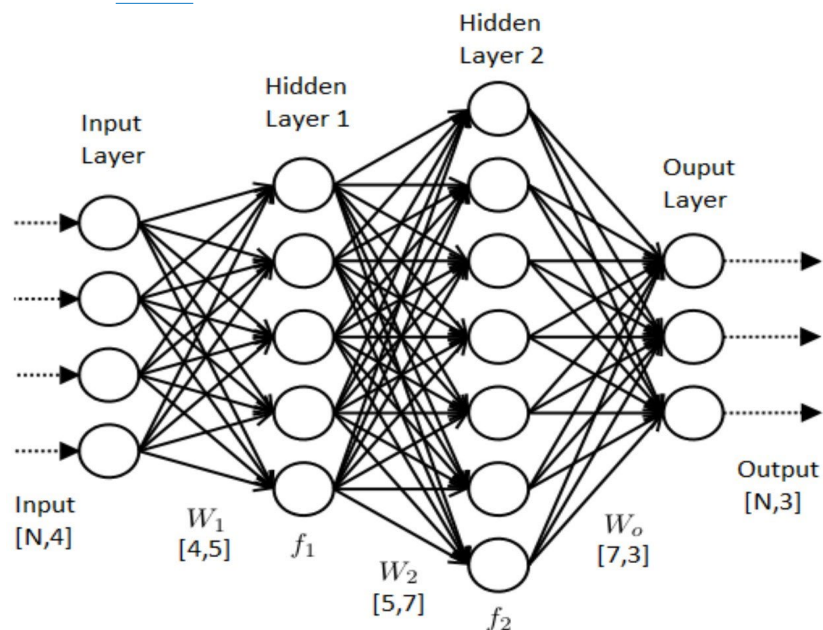

**BLACK BOX** AI

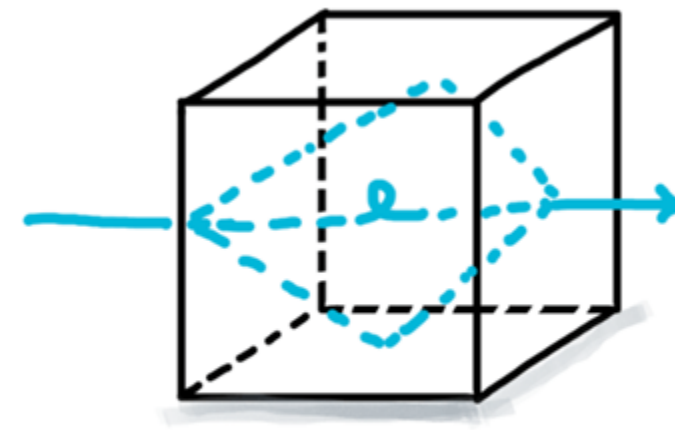

**EXPLAINABLE** AI

*"AI is a means, not an end. It has been around for decades but has reached new capacities fueled by computing power. This offers immense potential in areas as diverse as health, transport, energy, agriculture, tourism or cyber security. It also presents a number of risks. Today's proposals aim to strengthen Europe's position as a global hub of excellence in AI from the lab to the market, ensure that AI in Europe respects our values and rules, and harness the potential of AI for industrial use."* Commissioner for Internal Market Thierry Breton.

# The Need for eXplainable AI

It is not clear how variables are being combined to make predictions!



It has found some snow!

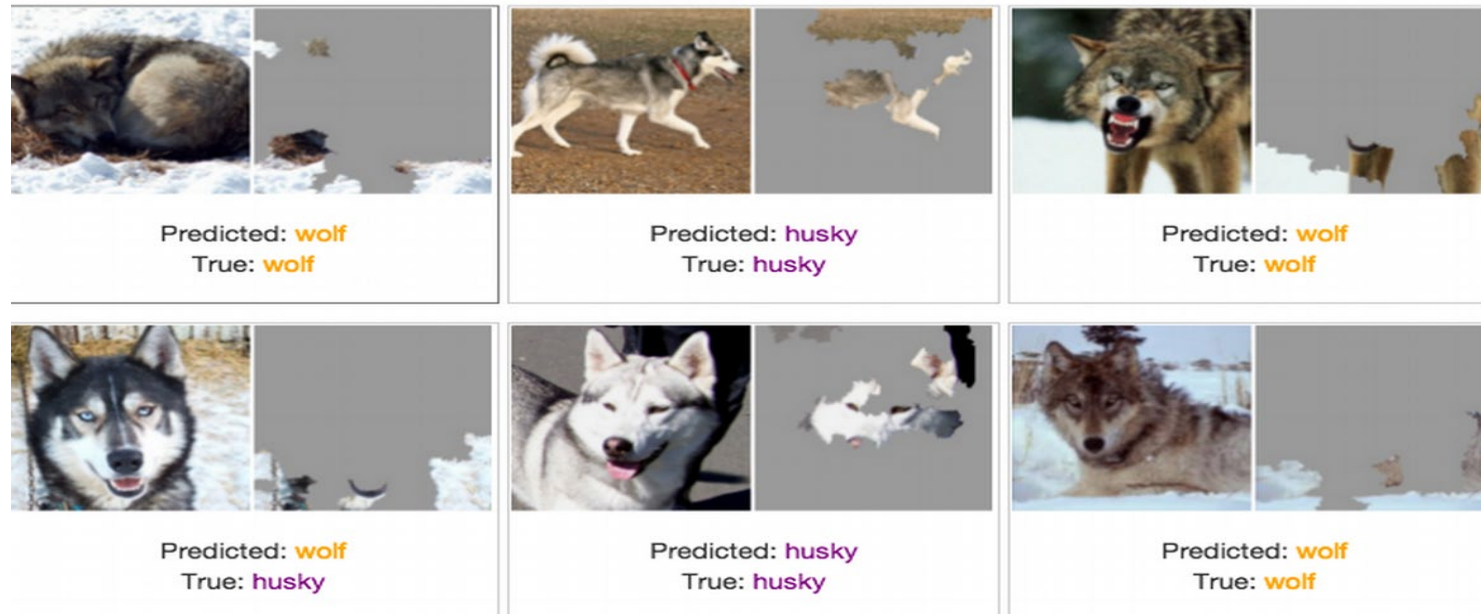

# Seven key requirements for AI systems

---



# Key regulatory requirements for AI systems I

---

## **Human agency and oversight**

AI systems should empower human beings, allowing them to make informed decisions and fostering their fundamental rights. At the same time, proper oversight mechanisms need to be ensured, which can be achieved through human-in-the-loop, human-on-the-loop, and human-in-command approaches

## **Technical Robustness and safety**

AI systems need to be resilient and secure. They need to be safe, ensuring a fall back plan in case something goes wrong, as well as being accurate, reliable and reproducible. That is the only way to ensure that also unintentional harm can be minimized and prevented.

## **Privacy and data governance**

Besides ensuring full respect for privacy and data protection, adequate data governance mechanisms must also be ensured, taking into account the quality and integrity of the data, and ensuring legitimised access to data.

# Key regulatory requirements for AI systems II

---

## **Transparency**

The data, system and AI business models should be transparent. Traceability mechanisms can help achieving this. Moreover, AI systems and their decisions should be explained in a manner adapted to the stakeholder concerned. Humans need to be aware that they are interacting with an AI system, and must be informed of the system's capabilities and limitations.

## **Diversity, non-discrimination and fairness**

Unfair bias must be avoided, as it could have multiple negative implications, from the marginalization of vulnerable groups, to the exacerbation of prejudice and discrimination. Fostering diversity, AI systems should be accessible to all, regardless of any disability, and involve relevant stakeholders throughout their entire life circle.

## **Societal and environmental well-being**

AI systems should benefit all human beings, including future generations. It must hence be ensured that they are sustainable and environmentally friendly. Moreover, they should take into account the environment, including other living beings, and their social and societal impact should be carefully considered.

# Key regulatory requirements for AI systems II

---

## **Transparency**

The data, system and AI business models should be transparent. Traceability mechanisms can help achieving this. Moreover, AI systems and their decisions should be explained in a manner adapted to the stakeholder concerned. Humans need to be aware that they are interacting with an AI system, and must be informed of the system's capabilities and limitations.

## **Diversity, non-discrimination and fairness**

Unfair bias must be avoided, as it could have multiple negative implications, from the marginalization of vulnerable groups, to the exacerbation of prejudice and discrimination. Fostering diversity, AI systems should be accessible to all, regardless of any disability, and involve relevant stakeholders throughout their entire life circle.

## **Societal and environmental well-being**

AI systems should benefit all human beings, including future generations. It must hence be ensured that they are sustainable and environmentally friendly. Moreover, they should take into account the environment, including other living beings, and their social and societal impact should be carefully considered.

## **Accountability**

It is closely linked to the principle of fairness. It necessitates that mechanisms be put in place to ensure responsibility and accountability for AI systems and their outcomes, both before and after their development, deployment and use.

# The European approach to trustworthy AI |

## AI Risks

- **Unacceptable risk:** AI systems considered a clear threat to the safety, livelihoods and rights of people will be banned. This includes AI systems or applications that manipulate human behaviour to circumvent users' free will and systems that allow 'social scoring' by governments.
- **High-risk:** AI systems identified as high-risk include AI technology used in:
  - Critical infrastructures
  - Educational or vocational training
  - Safety components of products
  - Employment, workers management and access to self-employment
  - Essential private and public services
  - Law enforcement
- Migration, asylum and border control management
- Administration of justice and democratic processes
- **Limited risk:** AI systems with specific transparency obligations: When using AI systems such as chatbots, users should be aware that they are interacting with a machine so they can take an informed decision to continue or step back.
- **Minimal risk:** The legal proposal allows the free use of applications such as AI-enabled video games or spam filters. The vast majority of AI systems fall into this category. The draft Regulation does not intervene here, as these AI systems represent only minimal or no risk for citizens' rights or safety.

*"AI is a means, not an end. It has been around for decades but has reached new capacities fueled by computing power. This offers immense potential in areas as diverse as health, transport, energy, agriculture, tourism or cyber security. It also presents a number of risks. Today's proposals aim to strengthen Europe's position as a global hub of excellence in AI from the lab to the market, ensure that AI in Europe respects our values*

# The European approach to trustworthy AI

## Unacceptable risk

- Clear threat to the safety, livelihoods and rights of people
- Systems or applications that manipulate human behaviour to circumvent users' free will
- 'social scoring' by governments

## High-risk

- Critical infrastructures
- Educational or vocational training
- Safety components of products
- Employment, workers management and access to self-employment
- Essential private and public services
- Law enforcement
- Migration, asylum and border control management
- Administration of justice and democratic processes

## Limited risk

- AI systems with specific transparency obligations
- Users should be aware that they are interacting with a machine so they can take an informed decision to continue or step back

## Minimal risk

- Free use of applications such as AI-enabled video games or spam filters
- The draft Regulation does not intervene here, as these AI systems represent only minimal or no risk for citizens' rights or safety

## Coordinated Plan on AI

- Funding allocated through the Digital Europe and Horizon Europe programmes, the Recovery and Resilience Facility and Cohesion Policy programmes
- Creation of enabling conditions for AI's development
- Foster AI excellence
- Ensure that AI works for people
- Build strategic leadership





# Quantum Computing

# AI and sustainability

## CO2 emission benchmarks

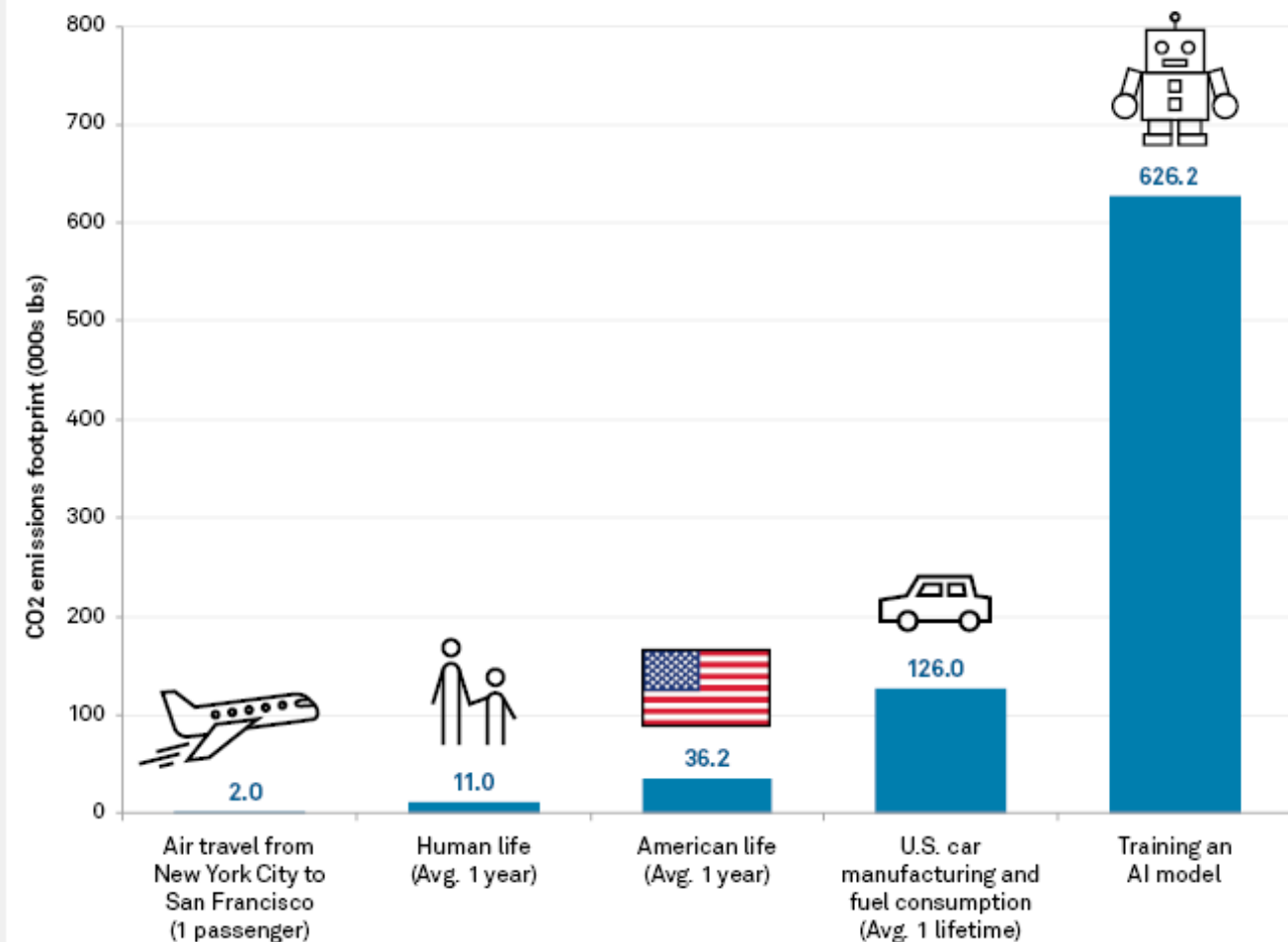

Data compiled Oct. 9, 2019.

An "American life" has a larger carbon footprint than a "Human life" because the U.S. is widely regarded as one of the top carbon dioxide emitters in the world.

Source: College of Information and Computer Sciences at University of Massachusetts Amherst

In 2030, using AI for climate control could help reduce

2.6 to 5.3 gigatons

of GHG emissions, or 5% to 10% of the total

and could provide

\$1 trillion to \$3 trillion

in value added when applied to corporate sustainability generally

Source: BCG analysis.

# How quantum computing could change financial services

In a Historic Milestone, Silicon Quantum Computing Just Exceeded 99% Accuracy

## JP Morgan Chase Unleashes Honeywell's Quantum Computer on Tough Fintech Problems

Quantum Computing in Banking and Finance – Threat or Opportunity?

### Quantum Computing Is Coming. What Can It Do?

by Francesco Bova, Avi Goldfarb, and Roger Melko

July 16, 2021

### First fully programmable quantum computer based on neutral atoms

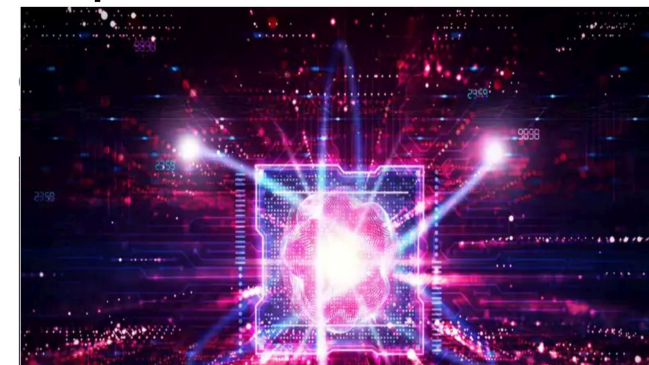

Bloomberg

Markets | Markets Magazine

## Quantum Computing Might Be Here Sooner Than You Think

## The potential of quantum computing for finance

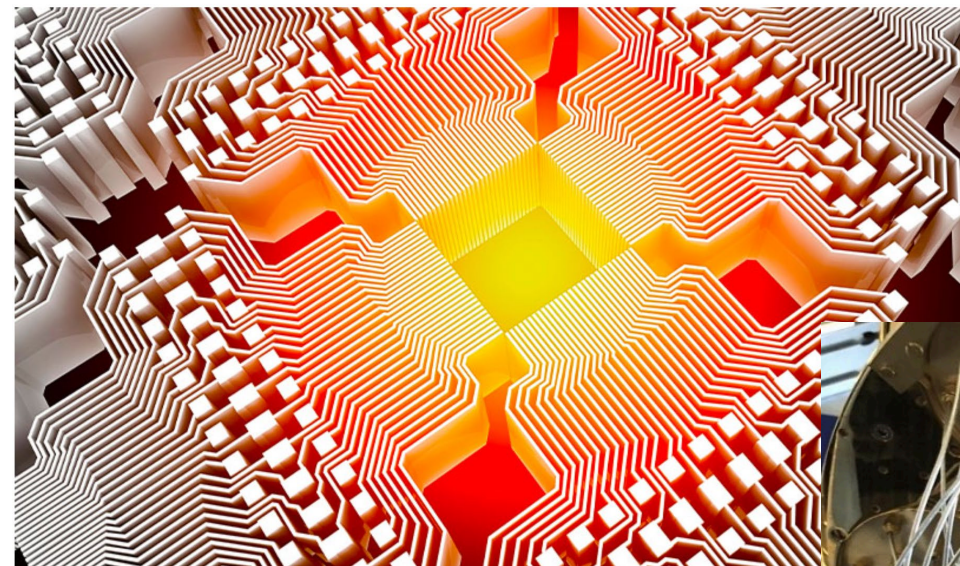

The first, and most important, is confirmation that quantum computers will be able to deliver processing power on an unimaginable scale.

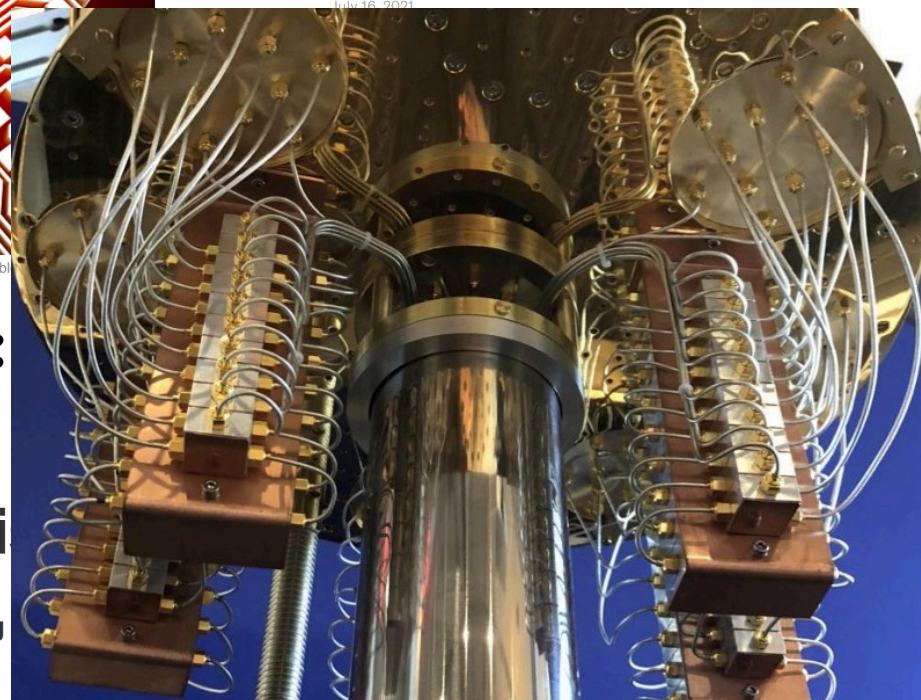

## Nuclear quantum computing:

Brought to you by the US Army

## Finland moves to industrialize quantum computing

For the Finnish government, now is the time to start preparing quantum computers will have practical value

# Vision of AI by 2050

*“[AI] is going to change the world more than anything in the history of mankind. More than electricity.”*— AI oracle and venture capitalist Dr. Kai-Fu Lee, 2018

Artificial intelligence is transforming how we design and build. By 2050, the effects of AI adoption will be widely felt across all aspects of our daily lives.

## **The Future of Work**

According to The Economist, 47% of the work done by humans will have been replaced by robots by 2037, even those traditionally associated with university education.

## **Urban Intelligence & Big Data**

55% of the world's population lives in urban areas, a number that will increase to 70% by 2050. AI can further analyze and monitor how

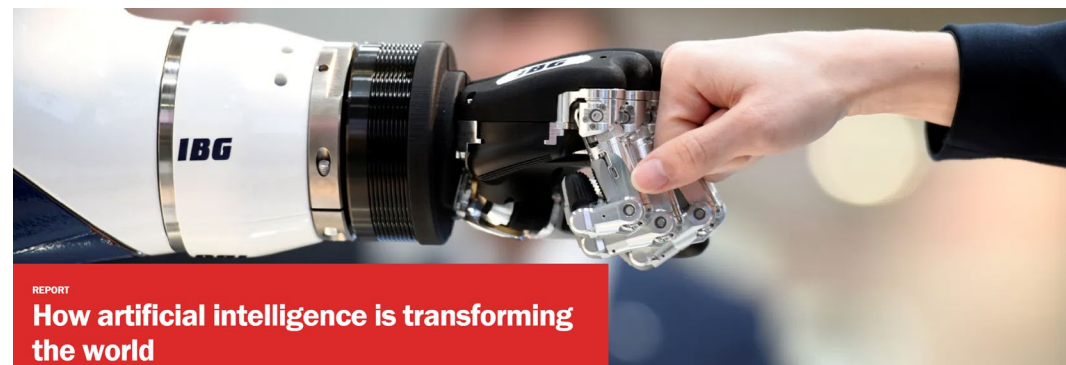

we move about the city, work together, and unwind. In 30 years, we will also have entirely new versions of these modalities.

## **Transportation**

Today, there is a lot of talk about the Hyperloop systems, with Virgin Hyperloop One and HyperloopTT emerging as the leading teams rethinking transportation. The implications for 2050 are dramatic, where our current ideas and associations of cities, geography and resources will radically change. At the same time, companies like Uber and Volocopter are looking to the sky to design and develop the world's first vertiport and air taxi hubs around the world. Trying to anticipate the future of mobility, the Third Dimension will open up new possibilities for transit.

# Vision of AI by 2050

## Construction

The report published by Balfour Beatty outlines a series of conclusions: robots will work in teams to build complex structures using dynamic new materials, while elements of a build will self-assemble. Drones flying overhead will scan the site, sending instructions to robotic cranes and diggers and automated builders with no need for human involvement. The result is a human-free construction process, one where the role of the builder moves to “overseer” and they are remotely managing projects.

## The Singularity

The Singularity is often defined as the point at which exponential technological advancements cross the threshold of “strong AI” and machines possess a broad intelligence that exceeds human levels. There is a very strong chance it will happen by 2050.



# The Future of Artificial Intelligence

---

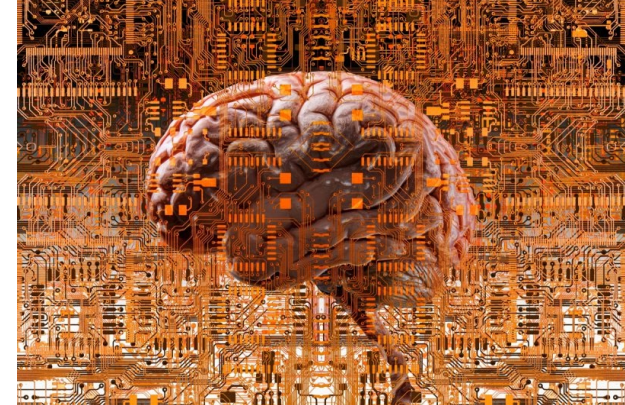

- *“The development of full artificial intelligence could spell the end of the human race....It would take off on its own, and re-design itself at an ever-increasing rate. Humans, who are limited by slow biological evolution, couldn't compete, and would be superseded.”— Stephen Hawking*
- *“Artificial intelligence would be the ultimate version of Google. The ultimate search engine that would understand everything on the web. It would understand exactly what you wanted, and it would give you the right thing. We're nowhere near doing that now. However, we can get incrementally closer to that, and that is basically what we work on.” —Larry Page*
- *“Artificial intelligence will reach human levels by around 2029. Follow that out further to, say, 2045, we will have multiplied the intelligence, the human biological machine intelligence of our civilization a billion-fold.” —Ray Kurzweil*



# Artificial Intelligence in Finance